

**Original instruction manual**  
**SBS Shotcrete Machine**  
**Type TSN / B1N**



Clever & Co.  
Elektro- und Maschinenfabrik GmbH  
Laubenhof 14-18  
45326 Essen

**Identification data****Machine / Plant**

Plant code: SBS Shotcrete Machine

Type: TSN / B1N

Order number / consignment:

Year of manufacture: 2010

**Customer entries:**

Company name:

Company address:

**Manufacturer's address:**Company name: Clever & Co.  
Elektro- und Maschinenfabrik GmbH

Street: Laubenhof 14-18

Town: 45326 Essen

Telephone +49 (2 01) 86 611 - 0

Fax: +49 (2 01) 66 08 - 74

**Replacement part orders and customer service:**Company name: Clever & Co.  
Elektro- und Maschinenfabrik GmbH

Street: Laubenhof 14-18

Town: 45326 Essen

Telephone +49 (2 01) 86 611 - 0

Fax: +49 (2 01) 66 08 - 74

E-mail [info@clever-co.de](mailto:info@clever-co.de)Internet address [www.clever-co.de](http://www.clever-co.de)

## Table of contents

1. General Information.....	4
1.1. Introduction.....	4
1.2. Information concerning copyrights and trademark rights .....	4
1.3. Information for the operating company.....	5
1.4. Briefing and training assistance .....	6
1.5. Examples of training topics .....	7
2. Safety.....	9
2.1. General Information .....	9
2.2. Sign and symbol information.....	9
2.3. Intended use .....	10
2.4. Residual risk .....	11
2.5. Description of the safety equipment .....	13
2.5.1. Emergency Stop.....	13
2.5.2. Dosing equipment limit switch .....	13
2.5.3. Blow-out flange limit switch .....	13
2.5.4. Securing of the danger points.....	13
2.6. Labels and signs on the SBS Shotcrete Machine.....	15
2.7. Safety information for operating personnel.....	16
2.8. Safety information concerning the operation of the SBS Shotcrete Machine .....	17
2.9. Safety information concerning maintenance and troubleshooting on the SBS Shotcrete Machine .....	17
2.10. Information concerning particular types of risk .....	18
2.10.1. Electrics .....	18
2.10.2. Hydraulics and pneumatics .....	18
2.10.3. Oils, greases and other chemical substances.....	19
2.10.4. Noise.....	20
3. Product description.....	21
3.1. General information .....	21
3.2. Functional process.....	22
3.3. Determination of the feed hose diameter for the output of the substance to be sprayed.....	23
3.4. Conveying air table .....	24
3.5. Technical data .....	25

---

4.	Transport and Installation .....	26
4.1.	General information .....	26
4.2.	Transport .....	26
4.3.	Shipment.....	27
4.4.	Requirements of the installation location of the SBS Shotcrete Machine.....	27
4.5.	Set-up of the SBS Shotcrete Machine .....	27
4.6.	Tests before commissioning.....	28
4.7.	Pre-setting of the correct dosing equipment contact pressure .....	29
5.	Operation .....	30
5.1.	TSN / B1N Shotcrete Machine control panel.....	31
5.2.	Display.....	34
5.2.1.	Start display .....	34
5.2.2.	"Maximum conveying vessel fill level" reached.....	35
5.2.3.	Error display .....	35
5.2.4.	"Settings" section .....	36
5.3.	Commissioning .....	37
5.4.	Machine operation .....	40
5.5.	Adjustment of the dosing unit.....	41
5.6.	Operational interruption.....	41
5.7.	Decommissioning.....	42
5.8.	Winter operation.....	43
5.9.	Errors.....	44
5.9.1.	Machine errors .....	44
5.9.2.	Errors in the spray nozzle area.....	53
6.	Maintenance.....	54
6.1.	Care.....	55
6.2.	Machine cleaning .....	55
6.2.1.	Machine cleaning requirements.....	56
6.2.2.	Machine cleaning sequence .....	56
6.3.	Service.....	58
6.3.1.	General service instructions .....	58
6.3.2.	Safe servicing of electrical equipment .....	59
6.3.3.	Safe servicing of hydraulic / pneumatic equipment.....	59
6.3.4.	Wear parts .....	60

---

6.3.5.	Lubrication plan.....	60
6.3.6.	Oil change.....	61
6.3.6.1.	Planetary gear (drive for dosing equipment) .....	61
6.3.6.2.	Worm gear (drive for pocket wheel).....	61
6.3.6.3.	Hydraulic oils .....	61
6.3.6.4.	Hydraulic oil filter .....	61
6.4.	Repair .....	61
6.4.1.	Dismantling the dosing unit .....	62
6.4.2.	Dismantling the dosing unit housing .....	63
6.4.3.	Assembly of the dosing unit housing .....	63
6.4.4.	Assembly of the dosing unit.....	64
6.4.5.	Replacing the wear plate .....	65
6.4.6.	Replacing the pocket wheel.....	66
7.	Disposal .....	67
7.1.	Environmental protection .....	67
7.2.	Oil and oil-containing waste, lubricating greases.....	67
7.3.	Plastics .....	67
7.4.	Metals .....	67
7.5.	Electrical and electronic waste .....	68
7.6.	Final decommissioning.....	68
8.	Appendix .....	69
8.1.	Declaration of conformity .....	70
8.2.	Assembly drawings .....	71
8.3.	Parts list.....	75
8.4.	Hydraulic plan .....	76
8.5.	Electrical plan .....	77

## **1. General Information**

### **1.1. Introduction**

This instruction manual is a significant aid with regard to the correct and risk-free operation of the SBS Shotcrete Machine.

The instruction manual contains important information on how to safely, properly and economically operate the SBS Shotcrete Machine. Observing this manual aids in reducing dangers, repair costs, downtimes as well as increasing the reliability and lifetime of the SBS Shotcrete Machine.

The instruction manual must be available at all times and is to be read and applied by all persons assigned to undertake work on or with the SBS Shotcrete Machine. This includes the following:

- Operation and troubleshooting whilst in operation
- Maintenance (care, service, repair) and / or
- Transport.

### **1.2. Information concerning copyrights and trademark rights**

This instruction manual is to be handled confidentially and may only be made accessible to authorised persons.

The manual may only be entrusted to third-parties with the written permission of Clever & Co.

All documents are protected under copyright law. The forwarding and reproduction of documents, including excerpts, as well as a utilisation and disclosure of their contents is not permitted unless explicitly allowed in writing.

Violations are a punishable offence and will lead to claims for compensation. Clever & Co. reserves the right to execute commercial trademark rights.

### **1.3. Information for the operating company**

The instruction manual is an essential part of the SBS Shotcrete Machine. The operating company ensures that the operating personnel acknowledge this manual. Based upon national regulations concerning accident prevention and environmental protection, the operating company is to supplement the instruction manual with operating instructions, including information with regard to supervisory and reporting obligations concerning the observation of special operational characteristics, e.g. with regard to work organisation, work sequences and utilised personnel.

In addition to the instruction manual and the binding accident prevention regulations valid in the country of the operating company as well as at the operating location, the recognised technical regulations for safe and professional work are also to be observed.

The operating company may not undertake any changes, upgrades or conversions to the SBS Shotcrete Machine without the permission of Clever & Co.. This particularly applies to the installation and setting of safety equipment as well as safety valves and also applies to welding on load-bearing elements.

Replacement parts that are to be utilised must conform to the technical requirements defined by Clever & Co.. This is always guaranteed when dealing with original replacement parts.

Only use trained or briefed personnel for the operation, service, repair and transport of the SBS Shotcrete Machine. Clearly define the responsibilities of the personnel with regard to the operation, service, repair and transport.

### 1.4. Briefing and training assistance

As an entrepreneur / operating company, you are obliged to inform or to brief the operating personnel with regard to the existing legislation and accident prevention regulations as well as with regard to the existing safety equipment on the SBS Shotcrete Machine. This obligation also extends to safety equipment installed around the SBS Shotcrete Machine. At this point, the varying professional qualifications of the staff members are to be taken into account.

The operating personnel must have understood the briefing and it must be ensured that attention is paid to the briefing.

Only in doing so can it be ensured that your personnel work in a manner where they are aware of safety and risk issues. It should be checked on a regular basis that attention is paid to the briefing.

As an entrepreneur / operating company, you should therefore ensure that the participation of each staff member in a briefing is confirmed in writing.

Please find examples for training topics as well as a master copy of the confirmation form concerning the participation in the training / briefing on the next pages.

Please contact Clever & Co. to discuss conditions should there be a need to further train the operating personnel after the plant has been handed over to the operating company.



**1.5. Examples of training topics**

<b>1. Safety</b>
Accident prevention regulations General legislation General safety information Measures in the event of emergency Safety information for the operation of the SBS Shotcrete Machine Dealing with the safety equipment of the SBS Shotcrete Machine Safety equipment in the vicinity of the SBS Shotcrete Machine Meaning of symbols and signs
<b>2. Operation of the SBS Shotcrete Machine</b>
Dealing with the operating elements of the SBS Shotcrete Machine Explanation of the instruction manual for the operating personnel Particular experiences of the operating company in dealing with the SBS Shotcrete Machine Rectification of malfunctions
<b>3. Maintenance and service regulations</b>
Proper handling of cleaning agents, lubricants Particular experiences of the operating company in the areas of service, maintenance, cleaning and care of the SBS Shotcrete Machine Replacement of machine parts Service of .....

Confirmation of the briefing / training		
Topic of the briefing / training:		
Date:	Trainer:	Trainer's signature:
No.	Surname, Forename	Signature
1		
2		
3		
4		
5		
6		
7		
8		
9		
10		
11		
12		
13		
14		
15		
16		
17		
18		

## 2. Safety

### 2.1. General Information

The SBS Shotcrete Machine has been developed and constructed using the latest technology and in accordance with the recognised safety regulations. This machine serves to manufacture shotcrete.

Danger to the operator and other materials assets may occur whilst the SBS Shotcrete Machine is in operation. In addition to this, the functionality of the machine may be restricted in the following cases:

- When the machine is operated by untrained / unbriefed personnel,
- When the machine is not used according to its intended purpose and / or
- When the machine is not maintained correctly.

### 2.2. Sign and symbol information

In the instruction manual, the following names or signs and symbols are used for particularly important details:



#### **Danger**

This is a warning of an immediate dangerous situation with the inevitable consequence of extremely serious injuries or death if the indicated instruction is not exactly followed.



#### **Warning**

This is a warning of a risk of danger with a possible consequence of extremely serious injuries or death if the indicated instruction is not exactly followed.



#### **Caution**

This is a warning of a possible dangerous situation with the consequence of medium to slight injuries as well as damage to property if the indicated instruction is not exactly followed.



#### **Information**

This refers to useful information concerning safe and proper handling of the machine.

- Work and operating steps are labelled with bullet points. The steps are to be listed from top to bottom.
- Lists are labelled with dashes.

Information and symbols that are directly mounted on the SBS Shotcrete Machine such as warning signs, activation signs, component labels, etc. must be observed in all circumstances. This information may not be removed and must be kept in a completely legible state.

### 2.3. Intended use

The SBS Shotcrete Machine is filled with the following items:

- Various powdery, sandy, fine,
- oven-dried or pre-moistened compounds.

Using compressed air, these compounds are pneumatically fed through a feed hose to a spray nozzle using the thin-flow process where they are mixed with the mixing water and sprayed.

The SBS Shotcrete Machine is designed for the processing of shotcrete, spray mortar, refractory materials, SPCC mortar, fibre concrete and sand-blast gravel. Furthermore, the machine is also able to convey backfilling material such as sand and gravel.

Ensure that the stated technical data is taken into account and observed.



#### Information

The details given in the *Technical Data* Section in Chapter 3 and in the original documentation of the supplier products located in the Appendix are to be taken into account and observed.

The following information concerning:

- Safety
- Operation and control
- Maintenance and service

as described in this instruction manual must also be observed in order to guarantee that the machine is used as intended.

The SBS Shotcrete Machine may not be operated in an explosive atmosphere.

The SBS Shotcrete Machine may only be operated whilst in a stationary position. The operator must secure the SBS Shotcrete Machine with stop blocks.

**Caution**

The SBS Shotcrete Machine may only be operated provided that a relief vessel is connected.

A different utilisation or a utilisation beyond this is not considered to be intended usage. The operating company of the SBS Shotcrete Machine is exclusively liable for damage caused by such utilisation. This also applies to unauthorised amendments to the SBS Shotcrete Machine.

**2.4. Residual risk**

There is a residual risk during the operation of the SBS Shotcrete Machine, even when all safety regulations are observed. This residual risk is described below:

All persons that work on or work with the SBS Shotcrete Machine must be aware of these residual risks and follow the instructions that prevent these residual risks from leading to accidents or damage.

It may be necessary to dismantle on-site safety equipment during installation and equipping works. As a result, various residual risks and the potential for danger occur that each operator should be aware of:

**Danger**

**Danger to life via electric shock.**

- **Ensure that the SBS Shotcrete Machine has been switched in to a current-free state via the main switch before undertaking any repair, installation or service works.**
- **Disconnect the mains plug**

**Warning**

**Allergic reactions may occur as a result of alkaline cement**

**The percentage of chromate in the SBS Shotcrete Machine starting mixture can cause allergic reactions (bricklayer's itch)**

- **When working with the SBS Shotcrete Machine, ensure that the stipulated personal protective equipment (eye protection, cement-resistant gloves, safety shoes, etc.) is used.**



**Warning**

**Eye injuries may be caused as a result of flying granulation**

**Flying granulation could cause significant eye injuries during the spraying process.**

- **When working with the SBS Shotcrete Machine, ensure that the stipulated personal protective equipment - eye goggles in particular - is used**



**Caution.**

**Risk of injury caused by uncontrolled feed hose movements.**

- **Only begin the spraying process when the spray nozzle is held tight by the nozzle operator.**

## 2.5. Description of the safety equipment

The SBS Shotcrete Machine has been constructed using the latest technology and in accordance with the recognised safety regulations.

Work on or with the SBS Shotcrete Machine may only be undertaken by specially trained personnel.

Take the SBS Shotcrete Machine out of operation via the main switch before undertaking repair work. Remove the mains plug from the mains in order to ensure that the SBS Shotcrete Machine cannot be accidentally switched on.

The operator must be satisfied that no persons are located in the danger area of the SBS Shotcrete Machine during normal operation, troubleshooting and maintenance work.

### 2.5.1. Emergency Stop

Integrated single-channel emergency stop circuit with an emergency stop switch located on both the control panel as well as on the remote control.



#### Information

Only press the emergency stop switch in the event that people or the SBS Shotcrete Machine are at risk.

### 2.5.2. Dosing equipment limit switch

Type T1R safety limit switch with integrated person and machine protection, manufacturer: Schmersal.

### 2.5.3. Blow-out flange limit switch

Type BNS 250 safety sensor with integrated person and machine protection, manufacturer: Schmersal.

### 2.5.4. Securing of the danger points

All valve and manual shut-off valve movements take place within the fittings or are exclusively rotational movements taking place within closed housing.

### **Material loading hopper**

The material loading hopper possesses an access protection unit in the form of a permanently welded coarsely-meshed grate (40 x 40 mm), the distance between the grate and the crushing point measures at least 220 mm.

Only the points with which sacks can be opened are slightly sharpened on the sack opening device. All other edges and corners that can be reached are deburred or rounded. There is no risk of injury should any person brush these edges and corners with their hands or arms.

### **Dosing unit**

Access into the dosing unit from above is secured via the material loading hopper and its safety equipment.

The side covers of the dosing unit can only be removed with the aid of tools.

Access into the dosing unit from below is secured via the conveying chamber and its safety equipment.

The dosing equipment can be folded away to the side for cleaning purposes. The folding mechanism of the dosing equipment is monitored electrically. The monitoring system switches the entire machine off when the dosing equipment is folded away.

In the event that the dosing equipment is opened in order to allow cleaning works to take place, it is located in the upper final position above dead centre and cannot unintentionally snap shut.

### **Conveying chamber**

The conveying chamber is a closed housing. All conveying chamber covers and lids can only be removed with the aid of tools.

The blow-out flange is locked with the aid of wedges and is secured by means of forelocks. Furthermore, the safety sensor as described in Point 2.5.3. ensures that the entire machine is switched off after the blow-out flange has been opened.



## 2.6. Labels and signs on the SBS Shotcrete Machine

### Sign / Meaning

### Mounting point

		Laubenhof 14-18	
Elektro- und Maschinenfabrik GmbH		45326 Essen / Germany	
		Tel.: +49/ (0)201/ 83 574-0	
		Fax: +49/ (0)201/ 83 574-44	
		www.clever-co.de	
<b>CE</b>			
Typ:	<input type="text"/>	Hydraulik:	<input type="text"/> bar
Masch.-Nr.:	<input type="text"/>	Pneumatik:	<input type="text"/> bar
Baujahr:	<input type="text"/>	Spannung:	<input type="text"/> Volt
Antrieb:	<input type="text"/>	Leistung:	<input type="text"/> kW

Clearly visible on the frame of the shotcrete machine



Warning against dangerous electrical voltage

Signs on all terminal boxes, switch boxes and low voltage switch cabinets.



Protective earthing connection

Next to the earthing screws



Wear eye, hearing and head protection

Clearly visible on the SBS Shotcrete Machine



Use protective gloves

Clearly visible on the SBS Shotcrete Machine



Use a dust mask

Clearly visible on the SBS Shotcrete Machine



Wear safety shoes

Clearly visible on the SBS Shotcrete Machine



Text panel: Take into account and observe information concerning PPE in the instruction manual, operating instructions or the safety data sheets belonging to the working materials utilised.

Next to the control panel

**Sign / Meaning**

Sling here

**Mounting point**Label for the transportation on the  
3 available slinging eyelets

## 2.7. Safety information for operating personnel

The SBS Shotcrete Machine may only be used provided that it is in perfect working order and provided that it is only used in accordance with its intended use in a safety and risk-conscious manner whilst observing this instruction manual. All faults, particularly those that can compromise safety must be immediately rectified.

Every person who is assigned to undertake commissioning, operation or maintenance work must have completely read and understood this instruction manual, particularly Chapter 2 entitled *Safety*. It is too late to do this during the work assignment. This particularly applies to personnel who are only occasionally deployed to work with the SBS Shotcrete Machine.

The instruction manual must always be ready to hand at the SBS Shotcrete Machine.

No liability will be assumed for damage and accidents that are caused as a result of non-observation of the instruction manual.

The relevant accident prevention regulations as well as the further generally recognised safety and occupational health regulations are to be observed.

Responsibilities with regard to the various service and maintenance activities are to be clearly defined and observed. This is the only way to prevent inappropriate actions – particularly in dangerous situations.

The operating company obligates operating and service personnel to wear personal protective equipment. This includes eye, hearing and head protection as well as safety shoes, protective gloves and dust mask.

No long and untied hair, loose clothing or jewellery may be worn. Such attire poses a risk of hair being caught or being pulled in / carried along by moving parts.

The operating company ensures that workstations, access paths and gangways on the SBS Shotcrete Machine are slip-resistant.

The SBS Shotcrete Machine is to be stopped immediately and secured should safety-relevant changes on the machine become evident. Inform the responsible authority / person concerning this process immediately.

Store first aid equipment (first aid kit, eye wash bottles) within reach.

Inform people of the location and operation of fire extinguishers and take the possibilities with regard to fire detection and fire fighting into account.

Observe the information concerning service works whilst the SBS Shotcrete Machine is being serviced.

Work on the SBS Shotcrete Machine may only be undertaken by reliably trained personnel. Ensure that the legal minimum age is observed.

Only trained or briefed personnel may be deployed.

Personnel to be schooled, taught, briefed or are currently undergoing a general training may only be active with the SBS Shotcrete Machine provided that they are constantly supervised by an experienced person.

## **2.8. Safety information concerning the operation of the SBS Shotcrete Machine**

The SBS Shotcrete Machine may only be put into operation provided that the respective fixed guards and / or safety equipment complete with proximity device are installed and their functionality has been proven.

The SBS Shotcrete Machine may only be operated when all safety-related equipment - detachable safety equipment for example - is present, functional and undamaged.

Before the SBS Shotcrete Machine is switched on or is started up, it must be ensured that nobody is present in the danger area of the SBS Shotcrete Machine and is put at danger by the SBS Shotcrete Machine starting up.

The personnel are to become acquainted with the working environment around the SBS Shotcrete Machine before commencing work.

The SBS Shotcrete Machine may never be left unattended whilst in operation.

Stop and secure the machine immediately in the event of malfunctions. Ensure that faults are rectified immediately by skilled personnel who are trained for such tasks.

## **2.9. Safety information concerning maintenance and troubleshooting on the SBS Shotcrete Machine**

Observe the specified deadlines or those stated in the instruction manual with regard to recurring tests / inspections.

It is essential that the workshop is appropriately equipped for the implementation of maintenance measures.

Ensure that sufficient lighting is in place when undertaking maintenance works.

Ensure that loose screw connections are always tightened after service and repair works have been carried out. Where specified, use a torque wrench to tighten the screws that can be tightened in such a manner.

Ensure that dirt is cleaned from connections and screws in particular when commencing service / repair / care work.

Ensure that individual parts and larger components are carefully fastened and secured to the hoisting devices when being replaced so that any risk posed by such items is kept to a minimum. Only use suitable and technically flawless hoisting devices and load-carrying equipment with a sufficient lifting capacity.

Do not remain or work underneath suspended loads.

Do not use any aggressive cleaning agents. Use lint-free cleaning cloths.

Ensure that operating and auxiliary materials as well as replacement parts are disposed of in a safe and environmentally-friendly manner.

## **2.10. Information concerning particular types of risk**

### **2.10.1. Electrics**

Work on electrical equipment belonging to the SBS Shotcrete Machine may only be carried out by a skilled electrician or by briefed personnel under the guidance and supervision of a skilled electrician in accordance with the electrotechnical regulations.

Before opening the terminal box, the SBS Shotcrete Machine is to be switched off via the main switch and the mains plug is to be removed from the mains.

In the event that a fault develops on the electrical power supply, the SBS Shotcrete Machine is to be switched off immediately via the main switch and the mains plug is to be removed from the mains.

Only utilise original fuses with stipulated current strengths.

Electrical components that are to undergo inspection, service and repair work must be placed into a voltage-free state. Secure disconnected operating equipment from being accidentally or automatically switched back on (lock fuses, jam circuit breakers, etc.). When dealing with disconnected electrical components, first ensure that they are free of voltage and then isolate neighbouring live components. Ensure that design features are not altered during repair work, thereby reducing safety (e.g. do not reduce creepage / air paths or distances by means of insulation).

Should it be necessary to undertake work on live parts (only in exceptional cases), an additional person should be called upon to activate the main switch in an emergency. Only use insulated tools.

The perfect earthing of the electrical system must be guaranteed by means of protective earthing systems.

Regularly inspect cables for damage and replace if necessary.

### **2.10.2. Hydraulics and pneumatics**

Work on pneumatic and / or hydraulic equipment may only be undertaken by personnel who possess special knowledge and experience in the field of pneumatics / hydraulics.

When undertaking service works on the hydraulics, the service personnel must be completely acquainted with the hydraulic circuit diagram and functions and must also be briefed with regard to the possible consequences of an operating error.

All pipelines, hoses and screw joints must be inspected to ensure air-tightness on a daily basis. Stop the SBS Shotcrete Machine immediately and rectify the fault in the event of a leak. Clear up any spilled hydraulic fluid and correctly dispose of it.

Ensure that the accumulator circuits are unpressurised before undertaking work on hydraulic accumulators.

Ensure that the system sections and pressure lines that are to be opened are unpressurised before commencing repair works.

Before commencing service works, connections and screw joints belonging to the pneumatics and hydraulics are to be cleaned of all types of soiling and are to be rinsed after the service works have been completed if necessary.

The pneumatic system must be connected to a line complete with ball valve so that the SBS Shotcrete Machine can be disconnected from the energy supply.

The maximum permitted service life of the pneumatic / hydraulic hose line amounts to six (6) years, including any periods of storage. The period of storage may not exceed two years.

### **2.10.3. Oils, greases and other chemical substances**

When dealing with oils, greases and other chemical substances, ensure that valid regulations and the manufacturer's safety data sheets for these materials with regard to storage, handling, utilisation and disposal are taken into account and followed.

Wear protective equipment manufactured from suitable material when working with corrosive substances (protective goggles, rubber gloves, rubber boots, protective clothing).

Wash the affected area immediately with plenty of water in the event of contact with eyes or skin. Suitable equipment (eye wash bottle, wash basin, shower) must be available close to the workstation.

#### **2.10.4. Noise**

The A-weighted equivalent constant sound pressure level at the operating work stations during normal operation of the SBS Shotcrete Machine amounts to more than 80 dB(A).



#### **Information**

Use hearing protection when working with the SBS Shotcrete Machine.

### **3. Product description**



#### **Information**

All of the positions included refer to the overview drawing located in Chapter 8.2 entitled Assembly Drawings

#### **3.1. General information**



Image 3-1: SBS Shotcrete Machine TSN / B1N

### 3.2. Functional process

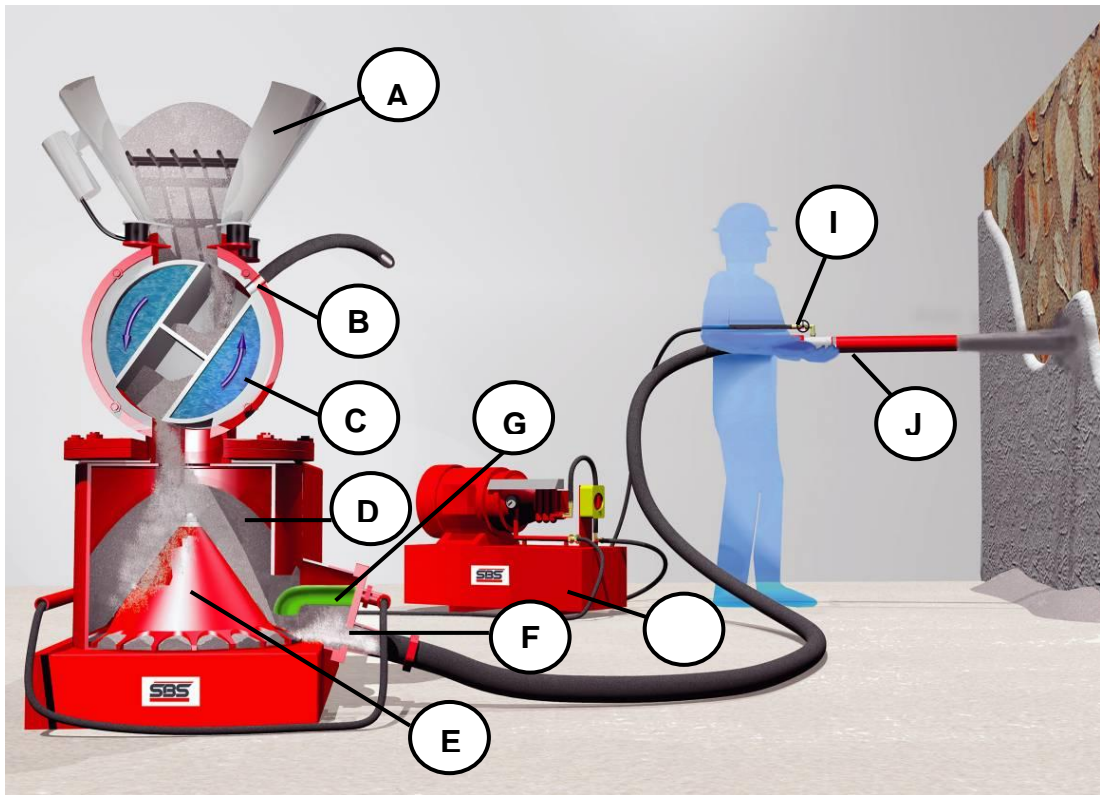

Image 3-2: Functional process

A	Material loading hopper	F	Discharge area
B	Exhaust	G	Injection nozzle
C	Dosing unit	H	PAN-DA high pressure pump
D	Conveying chamber	I	Mixing water
E	Pocket wheel	J	Spray nozzle

Pre-mixed spray material (moist or dry) is fed into the material loading hopper (A). The integrated screen prevents oversized grain from getting into the machine. The dosing unit (C) acts as a lock between the material loading hopper (A) and the conveying chamber (D) that is filled with compressed air. The pockets of the rotating dosing unit (C) fill the conveying chamber (D) with spray material. Compressed air that enters the machine when the pockets are being emptied is relieved via the exhaust (B). The fines that are carried along are retained by a filter bag located in the relief vessel (not shown). In order to seal the lock, the water-cooled, conical dosing unit is centrally pushed into an elastic seal with the aid of a manual adjustment device (not shown).



The spray material located in the conveying chamber is conveyed from pocket wheel (E) to discharge area (F). The air flow assumes the advanced spray material that has been dosed by the pocket wheel (E) and transports it through the feed line to the spray nozzle (J). When using the SBS "Ultra" High Pressure Mixing Spray Nozzle, the provision of the mixing water (I) is carried out via a PAN-DA High Pressure Pump (H).

The conveying air is blown in via the injection nozzle (G). By diverting the conveying air that has been blown in towards the discharge area (F), an air flow in the direction of the feed line and on to the spray nozzle (J) is created. The mixing water (I) is added at this point.

The amount of spray material that is to be fed into the air flow is determined by altering the speed of the pocket wheel (E).

The amount of conveying air is dependent upon the cross-section of the feed line, the conveying distance as well as the amount of spray material to be conveyed (see Chapter 3.4).

### **3.3. Determination of the feed hose diameter for the output of the substance to be sprayed**

The diameter of the feed hose should be adjusted to match the amount of spray material.

Oversized hose diameters increase rebound and also unnecessarily increase compressed air consumption.

Feed line diameter [mm]	Min. conveying output (practical values) [m <sup>3</sup> /h]	Max. conveying output max. (practical values) [m <sup>3</sup> /h]
25	0.3	0.7
32	0.7	2.0
38/40	1.5	3.0
50	3.0	5.0
65	5,0	15,0

### 3.4. Conveying air table

The compressed air requirement is dependent upon the feed line diameter, the conveying distance as well as the amount of material to be conveyed.

Feed line diameter (mm)	Conveying distance -horizontal- (m)	Compressed air <sup>(1)</sup> (m <sup>3</sup> /min)	Max. conveying output <sup>(2)</sup> (m <sup>3</sup> /h)
25	100	3	0.7
	200	4	0.4
32	100	4	2.0
	300	6	1.0
38/40	100	7	3.0
	300	8	2.5
	400	9	1.5
50	100	10	5.0
	300	12	4.0
	500	14	3.0
	700	16	2.0
65	100	18	8,0
	500	22	4,0
	700	24	3,0

<sup>(1)</sup> Compressed air requirement = Compressor nominal capacity at 7 bar

<sup>(2)</sup> With a material intrinsic moisture of approx. 3 %

For long conveying distances over 700 up to 1500 m, a 10 bar compressor is required.

### 3.5. Technical data

Practical conveying output:	0.3 - 8	m <sup>3</sup> /h
Grain size of the aggregates:	0 - 16	mm
Material feed hose connection (internal diameter):	25, 32, 38/40, 50, 65	mm
Air requirement dependent upon the feed hose diameter, conveying distance:	3 - 24	m <sup>3</sup> /min.
Conveying distance:	up to 1500	m
Conveying height:	up to 150	m
Main drive:	15	kW
	400/690	V
	50	Hz
	28,5	A
Hydraulic pressure of the drive:	210	bar
Air pressure:	max. 10	bar
Dosing unit speed:	max. 23	min <sup>-1</sup>
Dosing unit pocket content:	2 x 4	Litres
Pocket wheel speed:	39	min <sup>-1</sup>
Sound power level – machine:	79,2	db (A)
Sound power level – relief vessel:	89	db (A)
Weight:	app. 1,1400	kg
<b>Dimensions</b>		
Length:	2,400	mm
Width:	910 / 1000	mm
Height:	1,300	mm

## 4. Transport and Installation

### 4.1. General information

The SBS Shotcrete Machine was delivered by Clever & Co. in order to be used in accordance with its intended purpose.

Whenever the SBS Shotcrete Machine has to be transported back to the manufacturer Clever & Co. for repairs for example, the information provided in the section entitled Shipment must be strictly observed.

### 4.2. Transport



Image 4-1: Type TSN / B1N mode of transport

The SBS Shotcrete Machine Type B1N possesses its own chassis, with which it can be moved for short distances.



#### Warning

**Life-threatening crushing possible whilst lifting and transporting the SBS Shotcrete Machine.**

**The SBS Shotcrete Machine may tilt and fall as a result of improper lifting and transportation.**

**The SBS Shotcrete Machine must be completely emptied and closed. This prevents a shift in the centre of gravity and the risk of tilting associated with this.**

**The SBS Shotcrete Machine may only be lifted with a forklift truck. The permitted load bearing capacity of the forklift truck may not be exceeded.**

**Never remain underneath suspended loads.**

#### Follow the steps below when transporting the machine:

- Remove the connecting cable mains plug and roll the cable up.
- Disconnect the supply hoses from the shotcrete machine.
- Lift the SBS Shotcrete Machine using the appropriate hoisting and slinging equipment.
- Only fasten the slinging equipment onto the specified points.

### **4.3. Shipment**

For repair and / or service purposes, the SBS Shotcrete Machine can be sent to Clever & Co. where necessary.

- Contact Clever & Co. in order to clarify the appropriate measures.

### **4.4. Requirements of the installation location of the SBS Shotcrete Machine**

- Maintain an appropriate distance to excavation zones and machines.
- Pay attention to sufficient lighting at the workstation.
- Ensure that dust-laden exhaust air coming from the dosing unit exhaust is diverted away from the workstation.
- Do not position the SBS Shotcrete Machine in danger zones where it could be placed at risk as a result of the subsurface being instable.
- Do not position the SBS Shotcrete Machine in danger areas where materials could fall down onto the workstation.

### **4.5. Set-up of the SBS Shotcrete Machine**

- Secure the SBS Shotcrete Machine from rolling away by utilising stop blocks.
- Connect the exhaust of the shotcrete machine (6) with the relief vessel via the exhaust hose (7). Ensure that an intact filter bag (26) is used and protect this bag against moisture by using the plastic covering (58).
- Lay feed lines using the shortest route possible.
- The compressed air compressor and the connecting hoses must be sufficiently dimensioned (see 3.4 entitled Conveying Air Table).
- An air vessel must be installed between the compressor and the spraying machine in the event that additional air consumption units are connected.
- In the event of high moisture content inside the compressed air supply and the associated risk of the spray material sticking in the shotcrete machine, an additional water separator between the compressor and the machine is to be installed. Install this water separator as close as possible prior to the shotcrete machine.
- The concrete mixing water must be fed through the SBS Shotcrete Machine as a "cooling water". For this purpose, connect the 3/4" water inlet (12) with the construction site water pipe (max.10 bar).
- Connect the 3/4" water outlet (14) with the further water supply to the spray nozzle.
- Connect the water outlet (13) with the PAN-DA device when using an SBS mixing spray nozzle. Then connect the PAN-DA device to the mixing spray nozzle via a high pressure water hose.

**Information**

- During operation of the SBS Shotcrete Machine, ensure that the mixing water is fed through the SBS Shotcrete Machine, otherwise the dosing equipment will overheat. The consequence of this would be the blocking of the machine and that the machine wear would significantly increase.

**Information**

The position numbers are based upon the overview drawing located in Chapter 8.2 entitled Assembly Drawing.

- Establish the electric plug connection (32 A CEE Plug).
- Check whether the rotary field of the machine is correct by briefly switching the machine on. The following error message will appear in the control panel display should the rotary field be incorrect: "Incorrect rotary field". Where necessary, the rotary field can be changed in the phase inverter of the 32 A CEE Plug (48) with the aid of a screwdriver.

#### 4.6. Tests before commissioning

**Information**

The following position numbers are based upon the overview drawing located in Chapter 8.2, Images (8-1, 8-2, 8-3).

**Carry out the following tests before commissioning:**

- Check the hydraulic oil level on the fill level display (19). In the event that the lower edge of the viewing window does not display any oil, the hydraulic oil must be refilled (see "Lubrication Plan / Hydraulic Oils").
- Check that the wedge (20) belonging to the dosing equipment is tightly fitted and secure with forelocks (21).
- Also check that the wedges (22) located on the blow-out nozzles (11) are tightly fitted and secure with forelocks (36).
- Check whether the relief valve (31) and the drainage valve (32) are closed.
- Using the fill level display (29), check whether sufficient smooth running agent is in the tank. Only Clever & Co smooth running agent (Article Number 102283) may be used.

**Information**

The level of wear will increase and the dosing unit can jam should a different smooth running agent be used. Furthermore, Clever & Co will not assume any guarantee for possible damage caused by such actions.

**4.7. Pre-setting of the correct dosing equipment contact pressure**

Proceed as below in order to sufficiently pre-stress the dosing equipment: (no spray material is located in the spraying machine)

1. Switch on the main switch (40).
2. Press the illuminated push button (41).
3. Switch the "machine" rotary switch (44) located on the control panel from "0" to "2" via "1".
4. Check the hydraulic manometer (37) to see whether the hydraulic pressure amounts to approx. 60 – 70 bar. If required, correct the hydraulic pressure by rotating the "tension" (clockwise) or "loosen" (anticlockwise) buttons on the adjustment device (30) using the tension lever (57) supplied.
5. Switch off the main switch (40). The machine is now ready for commissioning.

## 5. Operation

- Only use trained or briefed personnel.
- Clearly define the responsibilities of the personnel with regard to the operation, installation, equipping and maintenance.
- Also define the area of responsibility of the operator and allow this person to reject unsafe instructions from third-parties.
- The operating personnel must be informed / briefed with regard to existing legislation and accident prevention regulations on and around the SBS Shotcrete Machine.
- The operating personnel must have understood the briefing and it must be ensured that attention is paid to the briefing.
- Only in doing so can it be ensured that the personnel works in a manner where they are aware of safety and risk issues.



### 5.1. TSN / B1N Shotcrete Machine control panel

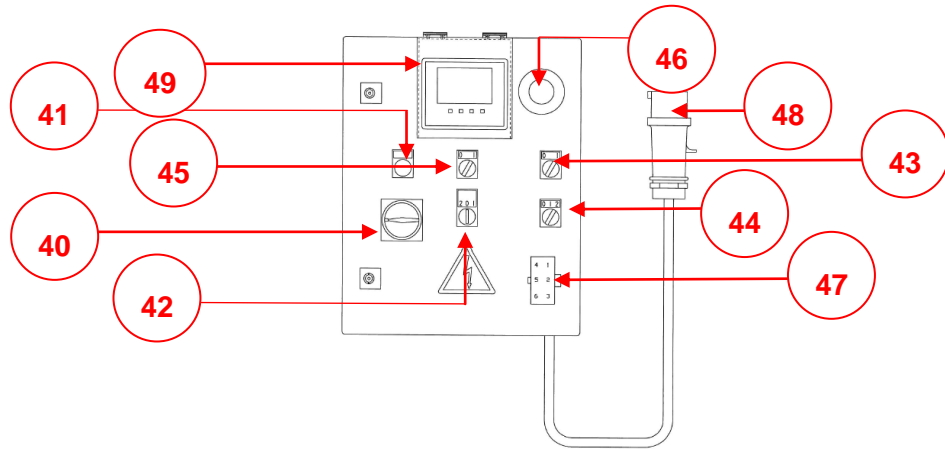

Image 5-1: Type TSN / B1N control panel

No.	Description	Function
40	Main switch	Disconnects the SBS Shotcrete Machine from the mains.
41	Illuminated push button	Main motor on / off
42	Key switch with three positions	Left: Control panel is active, operation is only possible via the machine Centre: 0 Right: Remote control is active, operation is only possible via the remote control
43	Rotary switch with two positions	0: Compressed air off 1: Compressed air on
44	Rotary switch with three positions	0: Pocket wheel and dosing unit off 1: Pocket wheel switched on 2: Dosing unit activated
45	Rotary switch with two positions	0: Vibrator off 1: Vibrator on
46	Emergency stop switch	Switches the entire machine off in the event of danger
47	Coupler base	Remote control interface
48	32 A CEE Plug	Connector plug for power supply
49	Display	Interactive display and input unit for various operating states and fault messages

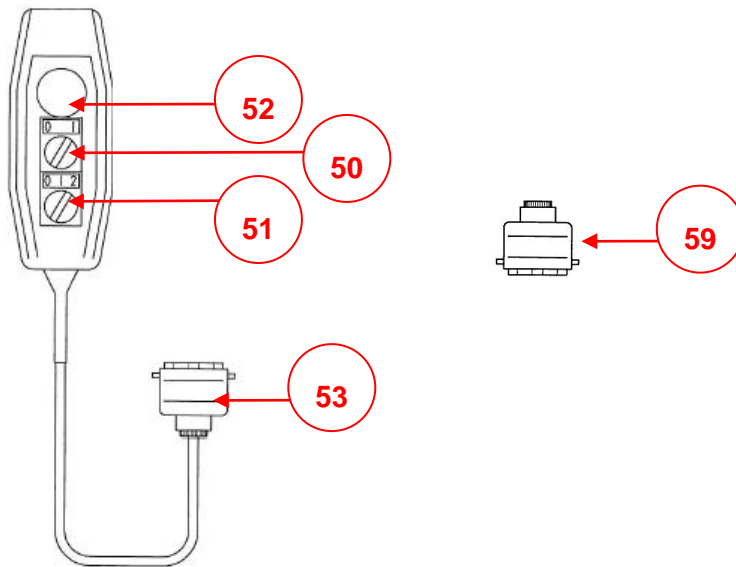

Image 5-22: Hand-held control unit



### Information

In the event that the machine is put into operation without a remote control, it must be guaranteed that the dummy plug (59) is positioned in the coupler base (47). If the dummy plug is not positioned in the coupler base, the electric safety circuit is interrupted and the spraying machine cannot be put into operation.

No.	Description	Function
50	Rotary switch with two positions	0: Switch off compressed air 1: Switch on compressed air
51	Rotary switch with three positions	0: Pocket wheel and dosing unit off 1: Switch on pocket wheel 2: Activate dosing unit
52	Emergency stop switch	Switches the entire machine off in the event of danger
53	Coupler plug	Remote control interface
59	Dummy plug	Cable bridge for safety circuit, required when working without remote control

## 5.2. Display

The "Siematic KTP 400" control panel integrated into the display serves to provide visual information to the machine operator with regard to important operating states of the shotcrete machine. The error messages shown on the display can be acknowledged and language settings can also be altered via the touch panel.

### 5.2.1. Start display

The following start display is shown on the display after the shotcrete machine has been switched on via the main switch (40) and illuminated push button (41):

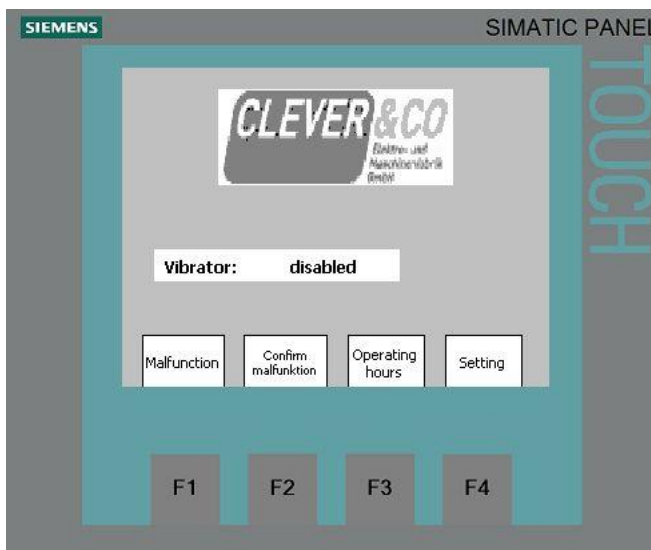

The following start display is shown on the display in case one of the rotary switches for air (50;43) or machine (51;44) is in position "1" or "2"

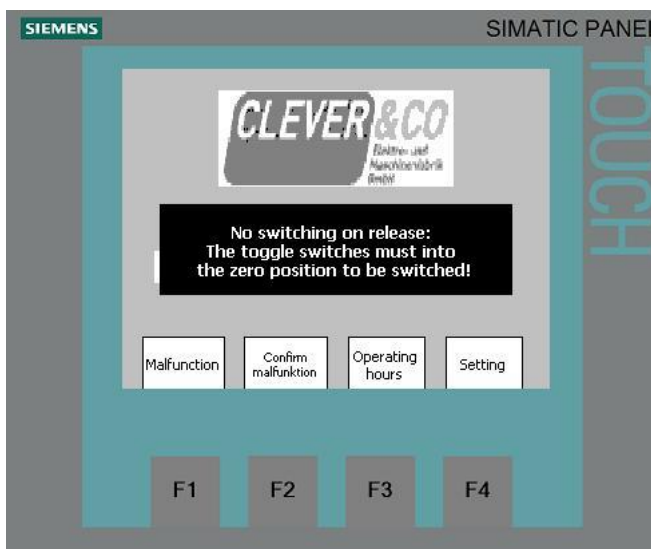

### 5.2.2. "Maximum conveying vessel fill level" reached

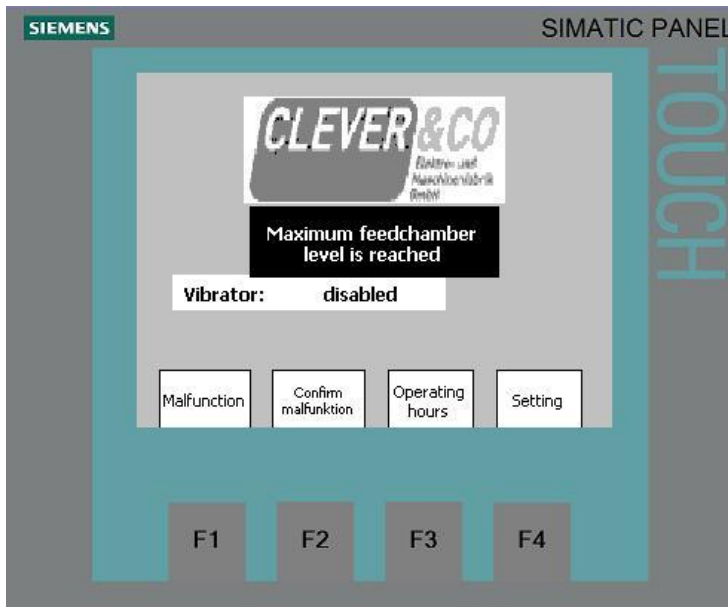

This display only is shown by using the machine with the optional rotary paddle switch.

### 5.2.3. Error display

The user can gain access to the error display by pressing the **F1** function key when on the start display.

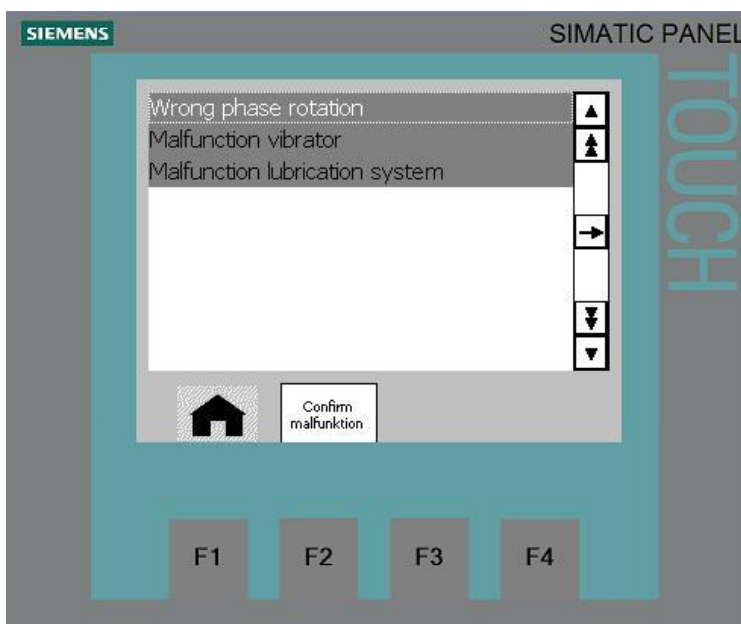

#### 5.2.4. "Settings" section

The user can gain access to the "Settings" section by pressing the F4 function key. The display language can be set and the lamps can be tested via the **F2** "Test Lamps" function key.

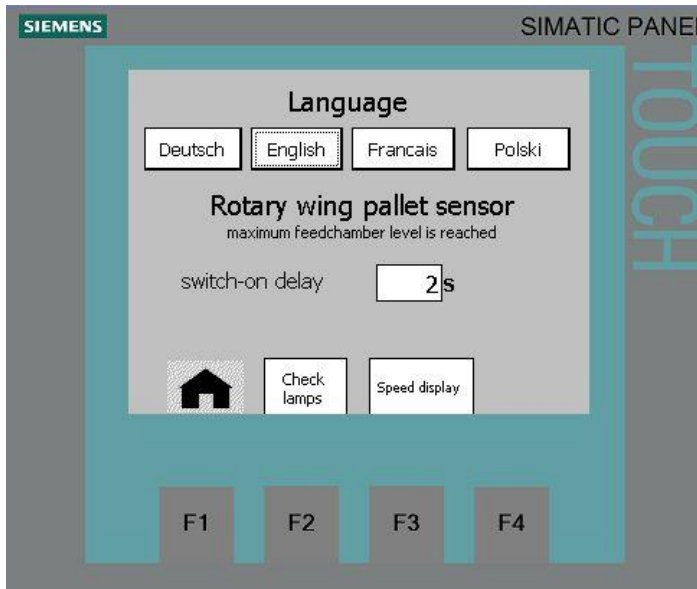

### 5.3. Commissioning



#### Warning

Allergic reactions may occur as a result of alkaline cement

The percentage of chromate in the SBS Shotcrete Machine starting mixture can cause allergic reactions (bricklayer's itch)

- When working with the SBS Shotcrete Machine, ensure that the stipulated personal protective equipment (eye protection, cement-resistant gloves, safety shoes, etc.) is used



#### Warning

Eye injuries may be caused as a result of flying granulation

Flying granulation could cause significant eye injuries during the spraying process.

- When working with the SBS Shotcrete Machine, ensure that the stipulated personal protective equipment - eye goggles in particular - is used



#### Caution.

Injuries caused by uncontrolled movement of the feed hose.

- Only begin the spraying process when the feed hose together with the spray nozzle is held tight by the nozzle operator.

**Information**

Establish perfect communication with the nozzle operator.

At least 2 staff members must always work simultaneously:

- One staff member is the nozzle operator who holds the feed hose and regulates the mixing water supply - this staff member may also possess a remote control (optional).
- A further staff member is stationed on the control panel, determines the conveying quantity as well as the conveying air together with the nozzle operator and refills material from sacks where necessary.

It is not necessary to have further personnel constantly filling the machine in the event of silo feeding with automatic fill level monitoring (silo scope of supply / material manufacturer).

**In order to start the shotcrete conveying, now put the SBS Shotcrete Machine into operation in the sequence shown below (machine operation via the control panel).**

- Ensure that the "machine" rotary switch (44) as well as the "air" rotary switch (43) located on the control panel (17) are on position 0.
- Half-open the 1/2" (24) ball valve.
- Half-open the 1 1/4" (25) ball valve.
- Set the conveying quantity setting (27) to approx. 30% (this is approximately the position for 1/3 of the conveying output).
- Switch on the main switch (40).
- Press the illuminated push button (41).
- Place the spray material into the material loading hopper (1).

**Start of material conveying:**

- The nozzle operator completely opens the water control valve located on the spray nozzle (J).
- Switch the "air" rotary switch (43) from "0" to "1".
- Switch the "machine" rotary switch (44) from "0" to "2" via "1".
- When compressed air is emitted from the dosing equipment, the adjustment devices (30) must be rotated in an anticlockwise motion with the aid of the tension lever (57)  
(ideal pressure of the hydraulic system amounts to approximately 130 - 150 bar.)



**The shotcrete machine now conveys with a lower output.**

The conveying quantity is gradually increased in consultation with the nozzle operator:

1. In order to carry this out, gradually move the conveying quantity setting (27) towards the "+" whilst observing the compressed air manometer (29).
2. Whilst constantly consulting the nozzle operator, simultaneously set the desired conveying air quantity via the ball valve ("25).

**Information**

Too little conveying air quickly leads to blocking. Therefore, ensure that a reduction in conveying air via the ball valve (25) only takes place in a gradual manner and always remains 1 bar below the maximum available nominal pressure of the compressed air system.

In doing so, always observe the compressed air manometer (29).

In the event that too much conveying air is delivered, the rebound percentage increases due to a conveying speed being too high and the dust exposure also increases.

Due to the fact that the nozzle operator is responsible for the later concrete quality to a greater extent, this staff member is always to use their own discretion when determining the required conveying output as well as the required air quantity.

## 5.4. Machine operation

If the shotcrete machine is in operation and achieves the correct conveying quantity setting in consultation with the nozzle operator, the material conveying runs automatically. SBS Shotcrete Machine



### Information

The conveying chamber (5) must be constantly sufficiently filled with spray material in order to ensure uniform and shock-free material conveying. The filling quantity of the TSN / B1N can be automatically regulated with the optional rotary paddle switch (8) .

During operation, ensure that the screen (2) located in the material loading hopper (1) is kept free of oversized grain and that the loading hopper is always sufficiently filled with spray material.

The exhaust hose (7) must be able to freely extract the exhaust air, otherwise the compressed air from the dosing unit pocket (4) will be relieved into the loading hopper (1). The consequence of this is a lower performance and high production of dust.

The exhaust air is not freely extracted when the relief vessel (14) is overfilled. In order to not restrict the filtration effect of the filter bag (26), the bag must be protected against moisture in the event of wet conditions by using the plastic covering (58).



### Information

Whilst the SBS Shotcrete Machine is in operation, ensure that water is fed through the machine in order to cool the dosing equipment (see Chapter 4.5 entitled "Set-up of the shotcrete machine) and that the smooth running agent tank (35) is sufficiently filled with Clever & Co. smooth running agent (Article Number 102283).

If this is not ensured, there is a risk that dosing equipment will overheat, the level of wear increases and the dosing unit can jam. Furthermore, Clever & Co will not assume any guarantee for possible damage caused by such actions.

## 5.5. Adjustment of the dosing unit

- Ensure that no compressed air leaks from the dosing equipment (54) or from the material loading hopper (1).

Adjust the dosing unit where necessary:



### Caution.

**Serious damage may be caused to the SBS Shotcrete Machine.**

**The dosing unit (3) may jam if the pressure setting is too high.**

**The ideal operating pressure of the hydraulics amounts to between 130 and 150 bar. The hydraulic drive pressure, which is displayed on the manometer (37), may not exceed 150 bar.**

- For sealing purposes, tighten the adjustment device (30) in a clockwise direction with the tension lever (57) until no compressed air escapes from the dosing equipment.

## 5.6. Operational interruption

Proceed as follows in the event of brief operational interruptions:

1. Switch the rotary switch (44) to position "2" to position "1" (dosing unit is stopped, pocket wheel continues to run). After a few seconds, the compressed air manometer (29) displays a clear drop in pressure, the conveying chamber (5) and the feed line are now purged.
2. Now switch the rotary switch (44) from position "1" to "0". This stops the pocket wheel.
3. Switch off the compressed air via the rotary switch (43).
4. The nozzle operator undertakes the final step by switching the mixing water off at the spray nozzle.



### Information

The mixing water must always be switched off last when using the SBS "Ultra" High Pressure Mixing Spray Nozzle as the micro holes belonging to the mixing spray nozzle will otherwise become blocked.

## 5.7. Decommissioning

Proceed as follows in the event of a long-term operational interruption:

- Interrupt the material supply on the loading hopper in order to run the machine empty.
- Wait until a significant drop in pressure can be detected on the compressed air manometer (29).
- First switch the "machine" rotary switch (44) to "0".
- Then switch the "air" rotary switch (43) to "0".
- Switch off the main switch (40).

Secure the SBS Shotcrete Machine against unauthorised usage by:

- Disconnect the mains plug.
- Disconnect the SBS Shotcrete Machine from the compressed air supply.
- Disconnect the SBS Shotcrete Machine from the supply lines for compressed air and water after these lines were put into an unpressurised state.



### Information

The machine must be cleaned if the intended downtime amounts to more than one day. For more information regarding this issue, read Chapter 6.2. entitled "Machine cleaning".

## 5.8. Winter operation



### Caution.

**Water hoses can burst as a result of frozen water.**

**Remove all water from the SBS Shotcrete Machine when there is a risk of frost.**

- Disconnect all water hoses from the shotcrete machine during all downtimes in winter.
- Purge all water hoses with compressed air.
- Purge the residual cooling water from the SBS Shotcrete Machine by pressing the SBS Shotcrete Machine water inlet (12) with a compressed air nozzle until all residual water has exited the water outlet (13).



### Information

Ensure that you also observe take the "PAN-DA High Pressure Pump" instruction manual when using our PAN-DA High Pressure Nozzle System.

## 5.9. Errors

When dealing with errors, a distinction is drawn between errors concerning the shotcrete machine and errors concerning the spray nozzle. The errors concerning the shotcrete machine are dealt with first below. (Chapter 5.9.1.)

The following chapter (Chapter 5.9.2.) lists the errors concerning the spray nozzle.

### 5.9.1. Machine errors

<b>Error</b>	<b>Cause</b>	<b>Suggested solution</b>
<p>Machine cannot be switched on by pressing the illuminated push button (41).</p> <p>An error display is shown on the display on the control panel: "Incorrect rotary field"</p>	<p>Incorrect electric motor (18) rotary field.</p>	<p>Alter the direction of rotation with the aid of the phase inverter located on the CEE device plug.</p> <p>Acknowledge the error message by pressing the "F2" function button on the display.</p>
<p>Machine cannot be switched on by pressing the illuminated push button (41).</p> <p>An error display is shown on the display on the control panel: "Safety circuit interrupted"</p>	<p>Dosing equipment or blow-out flange are not sealed correctly. The electric safety circuit was interrupted by the respective safety switch.</p>	<p>Inspect the correct sealing of the dosing equipment or blow-out flange.</p> <p>Acknowledge the error message by pressing the "F2" function button on the display.</p>
	<p>One of the two emergency stop keys is activated</p>	<p>Release of the respective emergency stop key.</p> <p>Acknowledge the error message by pressing the "F2" function button on the display.</p>
<p>The shotcrete machine is not conveying any spray material</p> <p>The machine is unusually loud and the hydraulic manometer (37) is</p>	<p>Pocket wheel (8) is jammed with foreign objects or hard concrete.</p>	<p>Take the machine out of operation (see Chapter 5.6)</p> <p>Open the blow-out flange (38) and attempt to free the pocket wheel from foreign object with the aid of an assembly rod.</p>

<b>Error</b>	<b>Cause</b>	<b>Suggested solution</b>
displaying a pressure in excess of 210 bar. Dosing unit and pocket wheel are not rotating although the "machine" rotary switch (44) is set to position "2".		Open and clean the machine, remove hard concrete located underneath the pocket wheel as described in Chapter 6.2.
The shotcrete machine is not conveying any spray material  The machine is unusually loud and the hydraulic manometer (37) is displaying a pressure in excess of 210 bar. Dosing unit and pocket wheel are not rotating although the "machine" rotary switch (44) is set to position "2".	The adjustment device (30) is fastened too tight.	Reduce the contact pressure by loosening the adjustment device with the help of the tension lever (57) until the pressure on the hydraulic manometer drops and displays a maximum of 150 bar.
	The dosing equipment is not cooled with water; causing an excessive generation of heat. The dosing unit is jammed in the housing by a large expansion of the rubber lining.	Connect the water cooling to the dosing equipment (see Chapter 4.5).
	The dosing equipment is insufficiently lubricated. The smooth running agent pump (34) is not conveying any smooth running agent.	Check whether there smooth running agent pump has developed an error. The following error message is shown on the display on the control panel: "Smooth running plant error".  Inspect the smooth running agent fill level display (28), top up with smooth running agent where necessary.
Dosing unit (3) and pocket wheel (9) are not rotating, hydraulic manometer (37) is not displaying a pressure level.	The conveying quantity setting (27) is set too far towards the "- setting".	Set the conveying quantity setting (27) towards the "+" setting.

Error	Cause	Suggested solution
<p>Dosing unit (3) and pocket wheel (9) are not rotating, hydraulic manometer (37) is not displaying a pressure level.</p>	<p>Electrical control voltage has broken down. 15 kW motor is not rotating.</p>	<p>Inspect the control fuse and the motor circuit-breaker (17) located on the control panel.</p> <p> <b>Danger.</b> <b>Danger to life</b> <b>caused by electric shock.</b></p> <p><b>Only allow work on live parts to be carried out by an electrician.</b></p>
<p>Dosing unit (3) is not rotating, pocket wheel (9) is rotating. The hydraulic manometer (37) is displaying a pressure of 20-30 bar ("machine" rotary switch (44) set to position "2").</p> <p>The following message is shown on the display on the control panel: "Maximum conveying vessel fill level reached*"</p> <p>*only by using the optional rotary paddle switch</p>	<p>Due to the high fill level in the conveying chamber (5), the rotary paddle switch (8) has switched the dosing unit off.</p>	<p>No error. Wait until the fill level in the conveying chamber drops once again and the dosing unit starts up once again.</p>



Error	Cause	Suggested solution
<p>Dosing unit (3) is not rotating, pocket wheel (8) is rotating. The hydraulic manometer (37) is displaying a pressure of 20-30 bar ("machine" rotary switch (44) set to position "2").</p> <p>The following message is shown on the display on the control panel: "Maximum conveying vessel fill level reached**"</p> <p>*only by using the optional rotary paddle switch</p>	<p>The rotary paddle switch (8) is mechanically jammed or faulty due to hard concrete.</p>	<p>Take the machine out of operation (Chapter 5.6). After opening the shotcrete machine, carefully clean or, where necessary, replace the rotary paddle switch whilst wearing gloves but without using tools.</p> <p>Transitional operation is possible by installing a cable bridge between cable clamps "7" and "8" in the control panel (17).</p> <p> <b>Danger.</b> <b>Danger to life caused by electric shock.</b></p> <p><b>Only allow work on live parts to be carried out by an electrician.</b></p>
<p>Spray material is blown out from the exhaust (6).</p>	<p>Ball valve (25) is insufficiently opened; the pressure balance between the dosing unit pocket (4) and conveying chamber (5) required in order to empty the pockets is not created and the dosing unit pockets are not emptied correctly.</p>	<p>Open the ball valve (24) a little more.</p>

<b>Error</b>	<b>Cause</b>	<b>Suggested solution</b>
Spray material is blown out from the exhaust (6).	Due to the blow-out equipment (55) located behind the ball valve (25) being blocked, the pressure balance between the dosing unit pocket (4) and the conveying chamber (5) is not created and the dosing unit pockets are not emptied correctly.	Unscrew the blow-out equipment from the dosing unit housing and clean.
	Dosing unit housing (39) or dosing unit (3) are worn.	Take the machine out of operation (see Chapter 5.6). Open the dosing equipment and replace the dosing unit housing or dosing unit as described in Chapter 6.2.
	Unbalanced spray material grading curve with significant fine particle percentage.	Correct the causes for this separation, consultation with the material suppliers and arrange an inspection of the grading curve where necessary.
Intermittent material conveying during the spraying process.	The conveying chamber (5) is no longer sufficiently filled with spray material due to spraying material being stuck in the dosing unit pockets (4).	Clean the dosing unit pockets (4). See Chapter 6.2 entitled "Machine cleaning".
Intermittent material conveying during the spraying process.	Too much compressed air is supplied via the ball valve (24) belonging to the blow-out equipment (54) being excessively open.	Reduce the supplied quantity of air via the ball valve (24) (no large pointer fluctuations should continue to be visible on the compressed air manometer (29)).

<b>Error</b>	<b>Cause</b>	<b>Suggested solution</b>
	Due to the blow-out equipment (54) located behind the ball valve (24) being blocked, the pressure balance between the dosing unit pocket (4) and the conveying chamber (5) is not created and the dosing unit pockets are not emptied correctly.	Unscrew the blow-out equipment from the dosing unit housing and clean.
	The utilised compressed air compressor switches with too much pressure difference, the pressure fluctuations can be read on the compressed air manometer (29).	Utilisation of a suitable compressor. The pressure difference between switching the compressor on and off may not amount to more than 0.3 bar.
Compressed air leaks from the loading hopper (1) despite re-tensioning the adjustment device (30). The required operating pressure of the hydraulics of between 130-150 bar can no longer be set.	Spray material has entered the system between the rear side of the dosing unit (3) and the dosing unit housing (39) and is blocking the adjustment path.	Dismantle the dosing unit and clean the soiled area. (See Chapter 6.4.1)
	Dosing unit housing (39) or dosing unit (3) are worn.	Take the machine out of operation (see Chapter 5.6). Open the dosing equipment and replace the dosing unit housing or dosing unit as described in Chapter 6.4.
The conveying output of the shotcrete machine is insufficient.	The dosing unit and pocket wheel speed is too low.	Set the conveying quantity setting (27) towards the + setting.

<b>Error</b>	<b>Cause</b>	<b>Suggested solution</b>
	Spray material is stuck in the dosing unit pockets (4) or pocket wheel pockets (9).	Take the machine out of operation (Chapter 5.6). Clean the dosing unit pockets and pocket wheel pockets
	Blow-out equipment (55) or compensation line (56) are blocked.	Clean the blow-out line and compensation line.
	Compressed air supply or the compressor performance is insufficient.	Increased compressed air supply
	Feed line cross-section is too small.	Use a feed line with a larger cross-section.
	The vibrator (15) located on the loading hopper is not functioning, dosing unit pockets are not sufficiently filled with spray material.	Activate the electric vibrator via the rotary switch (45) on the control panel.
Blockage immediately after the shotcrete machine is switched on	The supplied quantity of compressed air is insufficient for the conveyed quantity of spray material.	Reduce the conveying quantity via the conveying quantity setting (27) or increase the conveying air quantity via the ball valve (25).

Error	Cause	Suggested solution
Blockage immediately after the shotcrete machine is switched on	<p>Concrete residue is in the feed line</p> <p>(it is often the case that concrete shells that can come loose in time settle at coupler connections that are not airtight)</p>	<p>Take the machine out of operation (Chapter 5.6).</p> <p>Open the relief valve (31) and wait until the remaining air pressure from the conveying vessel has escaped. For controlling reasons, observe the compressed air manometer (29).</p> <p>Open the feed line, locate and rectify the blockage.</p> <p> <b>Danger.</b> <b>Risk of injury.</b></p> <p><b>Before opening the feed line connections, it is essential that the relief valve (31) is opened in order to release the residual pressure in the system.</b></p> <p><b>Never open pressurised feed lines.</b></p>
	<p>The grain size of the aggregates is too large for the utilised feed line cross-section.</p>	<p>Use a feed line with a larger diameter.</p> <p>(Tip: The internal diameter of the feed line should be at least three times the diameter of the largest aggregate grain.</p>
Blockages occasionally occur during the conveying process	<p>The spray material is supplied with various intrinsic moistures.</p> <p>(Intrinsic moisture max. 5%)</p>	<p>Consultation with the spray material supplier in order to guarantee the required parameters.</p>

Error	Cause	Suggested solution
	Silo goods with microsilica admixtures are processed (increased separation tendency as a result of incorrect blow-in into the storage silo).	Consultation with the material supplier / silo train driver who is responsible for the blow-in of the spray material into the construction site silo.
	Oversized grain or foreign objects fall through the material screen (2).	Use of a material screen with a smaller mesh size.
	The compressed air carries along too much water. (Adhesions in the blow-out nozzle (11) area and the feed line).	Utilisation of a water separator between the compressor and the shotcrete machine.
	Concrete shells form on couplers on the feed lines that are not airtight leading to a reduction in the cross-section.	Replacement of defective seals on the coupler connectors.
	The compressor switches with pressure differences that are too high.	Utilisation of a suitable compressor. The pressure difference between switching the compressor on and off may not amount to more than 0.3 bar.
Blockages occasionally occur during the conveying process	Additional pick-ups in the compressed air system reduce the entire air quantity that is available, (often the case when a demolition hammer is operated on the same compressor at certain times for instance).	Avoidance of external compressed air losses by third-party devices.

### 5.9.2. Errors in the spray nozzle area

Error	Cause	Suggested solution
Dust occasionally occurs on the spray nozzle or the concrete is no longer uniformly mixed with water.	Intermittent material conveying is caused by the shotcrete machine during the spraying process.	Machine error. See suggested solutions under Point 5.8.1 entitled "Intermittent material conveying during the spraying process".
	Blocked water holes on the spray nozzles prevent water inflow.	Clean the water holes on the spray nozzle, replace the mix pipe where necessary.
	Separated spray material with an excessive fine particle percentage leads to an excessive water demand.	Correct the causes for this separation, consultation with the material suppliers and inspect the grading curve where necessary.
	Utilisation of standard low pressure nozzle technology in connection with oven-dried spray material (no complete mixture of the spray material possible).	Utilisation of Clever & Co. high pressure mixing spray nozzle technology
The spray material is not sufficiently moistened with water despite the water control valve located on the spray nozzle being fully open.	Water supply to the spray nozzle is insufficient.	Ensure that the water supply to the spray nozzle is sufficient with regard to quantity and pressure.



#### Information

Observe the "PAN-DA High Pressure System" instruction manual when using the Clever & Co. PAN-DA high pressure nozzle technology.

## 6. Maintenance

The Maintenance Chapter is divided up into three sections: Care, Service and Repair. This should make the planning of the respective maintenance works easier for you.

The instructions described are to be considered to be minimum requirements. Depending upon the operating conditions, further instructions may be necessary in order to keep the SBS Shotcrete Machine in an ideal condition. The intervals given are based upon a single-shift operation.

The service and repair works described in this chapter may only be carried out by specially trained repair personnel from the operating company.

Only skilled personnel who are trained in the respective specialised field may be deployed when undertaking service and repair works in specialised fields, e.g. electrics.

With regard to repairs and replacement part orders, we would like to refer to the drawings and parts list that form part of the documentation and can be found in Chapter 8 (Appendices).

Replacement parts that are to be utilised must conform to the technical requirements defined by Clever & Co.

**This is always guaranteed when dealing with original replacement parts.**

Ensure that the valid regulations and the manufacturer's safety data sheets as well as the instructions contained in the operating instructions from the operating company with regard to storage, handling, utilisation and disposal of gases, greases, oils and other chemical substances are taken into account and followed.

Ensure that operating materials and replacement parts are disposed of in a safe and environmentally-friendly manner.

Observe the safety information provided on the following pages.



## 6.1. Care

Essentially, the care of the SBS Shotcrete Machine is limited to the regular cleaning of all machine covers and surfaces from shotcrete residue and other deposits should be removed by wiping / brushing away. It may be required to blow the SBS Shotcrete Machine using a compressed air cleaning nozzle when dealing with more stubborn stains.



### **Caution.**

Incorrect cleaning of the SBS Shotcrete Machine can lead to malfunctions and damage.

Do not select any aggressive cleaning agents that corrode metal / plastic surfaces or hose connections.

Never clean sensitive components - e.g. switches, sealing surfaces - with coarse brushes and high mechanical pressure. Use lint-free cleaning cloths.

Never clean the SBS Shotcrete Machine with a water jet or high pressure cleaner.

Water-based industrial cleaners can be used without restriction.

Adequate care helps to keep the SBS Shotcrete Machine in a functional condition on a long-term basis.

- Thoroughly clean the external area of the SBS Shotcrete Machine at least once per week.

## 6.2. Machine cleaning

The residual spray material remaining in the machine will harden after a period of time due to the intrinsic moisture of the spray material or due to the air moisture.

Therefore, thoroughly clean the SBS Shotcrete Machine whenever high air moistures or spray materials with intrinsic moisture appear to stick within the machine.

Tools and resources such as scrapers, wire brushes and compressed air cleaning nozzles are particularly suitable for machine cleaning.

**Warning****Risk of injury.**

- **Proceed with extreme caution when undertaking the cleaning work described below**
- **It is imperative that you carry out the cleaning work in the described sequence:**

**6.2.1. Machine cleaning requirements**

- It must be ensured that the shotcrete machine with attached loading hopper (1) is still completely closed,
- that the conveying air is shut off,
- and that the compressed air relief valve (31) is open.

**6.2.2. Machine cleaning sequence**

- Switch on the main electric switch (40).
- Press the illuminated push button (41).
- By switching the rotary switch (44) on and off whilst the machine is closed and the funnel is attached, position one pocket (4) of the dosing unit (3) in such a manner so that it is completely visible to the loading hopper (1).
- Switch the main electric switch (40) to "0". Disconnect the mains plug.
- Remove the loading hopper (1).
- Clean the following:
  - the 1st dosing unit pocket (4)
  - the exhaust pipe (6) and the exhaust hose (7)
  - the loading hopper (1).
- Reposition the loading hopper (1) and screw tight.

**Warning**

**Moving machine parts can significantly injure your hands.**

**Ensure that nobody reaches into the SBS Shotcrete Machine with their hands during the positioning or cleaning process.**

Remove the wedge (20).

- Fold open the dosing equipment (54).
- Now clean the second pocket of the dosing unit (3) that can now be accessed.
- Loosen the wedges (22).
- Remove the blow-out flange (38).

- Clean the pocket wheel (9) and the conveying chamber (5) via the openings that have become free.
- Bring the pocket wheel pockets into the respective cleaning position by using an assembly bar.
- After thoroughly cleaning, reattach the blow-out flange (38).
- Reinsert the wedges (22).
- It is essential that you secure the wedges (22) with the forelocks (36).
- Close the dosing equipment.
- Install the wedge (20).
- Secure the wedge (20) belonging to the dosing equipment with the forelock (21).
- Inspect the blow-out equipment (55) and the compensation line (56) to ensure that the air passage is perfect.
- Empty the relief vessel (14) where required and check the functionality of the filter bag (26).
- Open the drainage valve (32) located on the frame of the spraying machine at least once per day in order to release condensation that may have accumulated.

The cleaning of the SBS Shotcrete Machine is completed.

## 6.3. Service



### Information

The position numbers are based upon the overview drawing located in Chapter 8.2.

### 6.3.1. General service instructions

A positive impact with regard to a high availability of the SBS Shotcrete Machine can be achieved by conforming to the suggested care and service intervals.

Regularly inspect the SBS Shotcrete Machine and inform those responsible for the SBS Shotcrete Machine when repair and service works are required.



### Warning

**Warning against serious physical injuries.**

**Inappropriate behaviour can lead to serious physical injuries, e.g. fingers or hand being torn off caused by the uncontrolled movement of individual of machine elements.**

**Repair and service works on the SBS Shotcrete Machine may only be carried out by trained and authorised qualified personnel whilst observing the safety information and the valid accident prevention regulations.**

Before undertaking repair and service works:

- Take the shotcrete machine out of operation as described in Chapter 5.6. The hydraulic system is unpressurised when the main motor is switched off.
- Remove the water hoses from the water inlet (12) and water outlet (13).
- Check that the hydraulic system is unpressurised via the manometer.
- Obtain a suitable tool and only utilise it provided that it is in the proper condition.
- Do not forget to only use original replacement parts where necessary and order such parts in good time.
- Carefully label components and pipelines before dismantling.

### 6.3.2. Safe servicing of electrical equipment

Only allow work to be carried out on electrical components by skilled electrician.



#### **Danger**

**Danger to life via electric shock.**

**Disconnect the mains plug before undertaking any repair, installation and service works.**

Regularly inspect the electrical equipment of the machine.

### 6.3.3. Safe servicing of hydraulic / pneumatic equipment

Only persons with special knowledge and experience with hydraulics / pneumatics are permitted to work on hydraulic / pneumatic equipment.



#### **Warning**

**Warning against serious physical injuries.**

**Inappropriate behaviour can lead to serious physical injuries, e.g. fingers or hand being torn off caused by the uncontrolled movement of individual of machine elements.**

- **Switch off the main switch and secure against being switched back on without authorisation.**
- **Ensure that system sections and pressure lines that are to be opened are unpressurised before commencing repair works.**
- Relieve the pneumatic system of pressure by opening the air relief valves located on the vessel and machine frame.
- Replace the hydraulic hose lines at appropriate intervals (6 years), even in the event that no safety-relevant faults can be detected.
- Check the hydraulic / pneumatic lines for chafe areas.
- Replace any damaged hoses and remove all possibility of chafing.
- Inspect the service unit for the pneumatics on a weekly basis. Top up the service unit with oil and drain the service unit if necessary.

### 6.3.4. Wear parts

All parts that come into contact with pressurised spray material and are subject to particular wear are labelled as wear parts.

#### Dosing equipment

If an increased amount of compressed air leaks on the dosing equipment or from the loading hopper (1):

- Attempt to improve the situation by tightening the adjustment device in a clockwise direction. (Hydraulic pressure increases).

If the maximum hydraulic operating pressure of 150 bar is reached and no improvement occurs, it is probably the case that the dosing unit (3) or the rubber seal belonging to the dosing unit housing is worn. This also applies when the required minimum hydraulic operating pressure (approx. 130 bar) cannot be achieved by tightening the adjustment device. Dosing unit (3) and dosing unit housing (39) can be replaced as described below.

### 6.3.5. Lubrication plan

Greasing:

- after 20 working hours:  
Pump 1 - 2 strokes of non-resin grease (roller bearing grease) into the 4 lubrication points using a hand lever press. Only use non-resin grease (roller bearing grease).

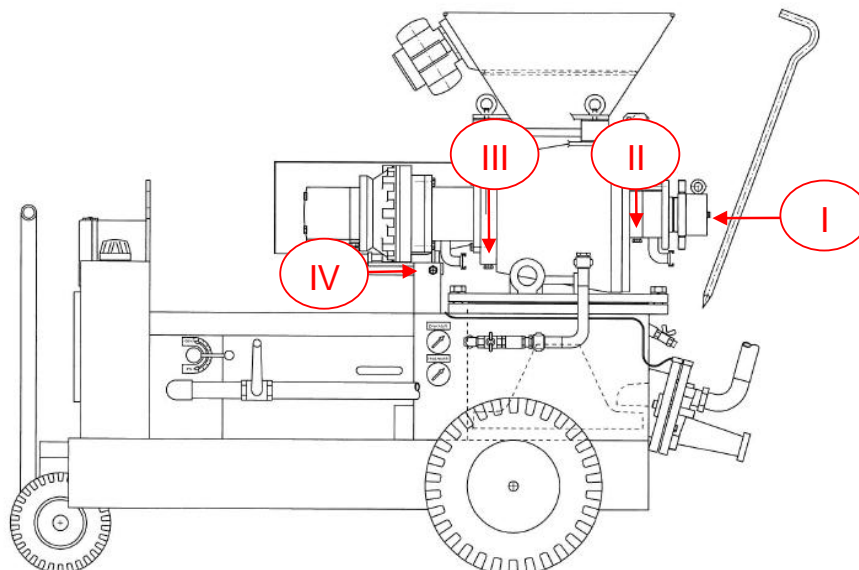

Image 6-1: Lubrication points

### 6.3.6. Oil change

#### 6.3.6.1. Planetary gear (drive for dosing equipment)

- After 500 operating hours:  
Oil change
- In the event of an oil loss: Top up HS 90 gear oil (filling quantity: 1 litre).

#### 6.3.6.2. Worm gear (drive for pocket wheel)

The gear is filled with long-term gear oil.

- In the event of an oil loss: Top up D 460 EP gear oil (1 litre).

#### 6.3.6.3. Hydraulic oils

Utilised hydraulic oil: Renolin B15 VG 46 (Order Number: 102116)

- After 1000 operating hours:  
Hydraulic oil change (filling quantity: approx. 65 litres).

#### 6.3.6.4. Hydraulic oil filter

- First change after approx. 50 operating hours;  
then together with the hydraulic oil change.

## 6.4. Repair

Repair works to the SBS Shotcrete Machine may only be carried out by trained and authorised skilled personnel from the operating company.

We recommend always arranging for the repair works to be carried out by Clever & Co. service technicians or by specialist companies authorised by the manufacturer.



### Information

The following issues apply during all extension and dismantling works:

- Label parts that belong with one another.
- Label / adhere to the installation position and location.
- Retighten all mechanical connections after reconstruction is completed.

#### 6.4.1. Dismantling the dosing unit



#### **Warning!**

**The dosing unit weighs 70 kg. There is a significant risk of injury through crushing should the dosing unit fall. Where possible, ensure that the dismantling / installation is carried out with the help of an assisting person. Where possible, ensure that resources such as pallet trucks or other hoisting devices are used.**

1. Using the tension lever (57), rotate the adjusting nut belonging to the adjustment device (30) in an anticlockwise direction until the limit stop is reached.
2. Take a ring spanner with a "24" spanner gap and loosen the 4 hexagonal bolts located on the housing cover. Completely remove these 4 screws.
3. Now take the ring spanner and rotate both of the "set screws" remaining in the housing cover in a clockwise direction until the housing cover visibly comes away from the dosing unit housing. (Photograph)
4. Using a ring spanner with a "30" spanner gap, loosen and remove the pressure screw belonging to the adjustment device. (Photograph) Completely remove the tommy nut belonging to the adjustment device and, in doing so, ensure that the cylindrical roller bearing is also removed.
5. Now remove the housing cover and set aside. Now - preferably with the help of a second person - pull the shaft stub of the dosing unit that is now visible from the dosing unit housing until the dosing unit pockets are free. Reach into the dosing unit pockets and now completely pull the dosing unit out of the housing and set aside.
6. Pay attention to the splined shaft that connects the dosing unit with the gear and set it aside.
7. Inspect the running surface of the dosing unit as well as the shaft ends for damage and grooves and insert a new dosing unit if required. (See Chapter 6.4.4.)



#### 6.4.2. Dismantling the dosing unit housing



##### **Warning!**

**The dosing unit housing weighs 86 kg. There is a significant risk of injury through crushing should the dosing unit fall. Where possible, ensure that the dismantling / installation is carried out with the help of an assisting person. Where possible, ensure that resources such as pallet trucks or other hoisting devices are used.**

1. Loosen the screw connection between the loading hopper (1) and dosing unit housing, remove the loading hopper.
2. Remove the wedge (20).
3. Using a spanner with a "17" spanner gap, loosen the 4 lubrication lines from the dosing unit housing.
4. Disconnect the exhaust hose (7) from the exhaust (6). Using a ring spanner with a "13" spanner gap, loosen the gear cover by removing the 3 M8 hexagonal bolts.
5. With the aid of water pump pliers, now rotate the drainpipe for the smooth running agent located on the rear housing wall out of the dosing unit housing.  
(Photograph)
6. Now use a spanner with a "24" spanner gap in order to disconnect the surge tank located between the gear and the dosing unit housing from the housing. After the hexagonal bolts have been unscrewed, the complete rear drive unit remains upon the bearing support connected to the machine frame.
7. Using a spanner with a "13" spanner gap, loosen the M8 hexagonal bolts for the hinged bolts belonging to the hinge that connects the lid of the conveying chamber with the dosing unit housing. Then hit the hinge pin out of the hinge mounting with the aid of an expelling pin. The dosing unit housing is now able to move freely on the conveying vessel and can be removed.

#### 6.4.3. Assembly of the dosing unit housing

1. Before assembling the dosing unit housing, ensure that the splined shaft in the planetary gear is fitted correctly.
2. Check both of the O-rings located in the surge tank and replace them if necessary. Grease the O-rings well when installing.
3. Now place the dosing unit housing back onto the respective position on the lid of the conveying chamber. Take the hinged bolts and push them through the respective openings in the dosing unit housing and the hinge mounting. Secure the hinge pin with the M8 hexagonal bolt.
4. Now push the flange belonging to the rear drive unit up to the limit stop located at the rear end of the dosing unit housing. Connect this drive unit with the dosing unit housing by tightening the 4 screws with a "24" spanner gap.

5. Screw the drainpipe for smooth running agent into the respective threaded hole once again using water pump pliers.
6. Place the gear cover back into its position and screw it tight using the 3 M8 hexagonal bolts. Reconnect the exhaust hose with the exhaust.
7. Reconnect the 4 lubrication lines to the respective connecting nipples located on the dosing unit housing.
8. Secure the dosing equipment from folding open by using the wedge (20).
9. Reassemble the loading hopper on the dosing unit housing. Check whether all screw connections are tightly fitted.

#### **6.4.4. Assembly of the dosing unit**

1. With one hand, guide the splined shaft through the rear bearing bush to the gear and push it into the multi-toothed bush until the limit stop is reached.
2. Apply a small amount of smooth running agent to the rubber sliding surfaces of the dosing unit housing.
3. Before assembly, inspect the dosing unit to ensure that it is clean and apply lubricating grease to the shaft stub. Lift the dosing unit - with the help of a second person where necessary - and guide the dosing unit with the rear shaft end into the bush of the dosing unit housing without tilting.
4. Now push the dosing unit with a slight rotation far back until it noticeably clicks into place on the multi-toothed shaft of the gear.
5. Apply lubricating grease to the front shaft stub. Check the slide bearing surface located in the front dosing unit housing lid and replace if necessary. Check the O-ring located in front of the slide bearing and both of the O-rings located in the front surge tank and replace if necessary.
6. Now push the dosing unit housing lid over the protruding front shaft stub until the limit stop on the dosing unit housing is reached and assemble the 4 hexagonal bolts. Fasten these in a criss-cross manner using a spanner with a "24" spanner gap.
7. Join the pressure screw and the lubricated slide bearing together in the tommy nut belonging to the adjustment device and then install the prepared tommy nut on the outside thread of the lid. Rotate the tommy nut in a clockwise direction using the tension lever until clear resistance can be felt. Tighten the pressure screw using a ring spanner with a "30" spanner gap.
8. Using the tension lever, loosen the tommy nut by approximately one rotation. The dosing equipment is now ready for operation once again.



#### **Information**

Take the explosion drawing of component 3 in the Clever & Co. Replacement Part List into account during assembly.

#### 6.4.5. Replacing the wear plate

A wear plate is located underneath the pocket wheel (9) on the base of the conveying chamber (5). This serves to protect the vessel base against grinding and must undergo a visual inspection on a monthly basis.

Should you discover that this wear plate is worn during a visual inspection:

Install a new wear plate in order to prevent damage being caused to the conveying chamber (5). Proceed as follows when undertaking this work:

1. Dismantle the dosing unit and dosing unit housing as described in Points 6.4.1. and 6.4.2..
2. Remove both of the wedges (22) and pull the entire blow-out flange (38) from the shotcrete machine.
3. Take a spanner with a "36" spanner gap and loosen all of the hexagonal bolts belonging to the lid to the conveying chamber (5). Also remove both of the slinging eyelets with which the lid was fastened to the conveying vessel. Remove the lid of the conveying chamber. Also loosen the internal hexagonal bolts that connect the conveying chamber with the lid in the area above the blow-out flange.
4. Unscrew the rotary paddle switch (8) from the conveying chamber.
5. Loosen and remove both of the M 12 (SW 19) hexagonal bolts as well as the cap nuts (SW 36) located on the upper pin end of the pocket wheel. Fasten the detaching device to the pocket wheel using two M12 hexagonal bolts and remove the pocket wheel from the shaft. Pay attention to feather keys that may fall down and collect them.
6. You should now be able to recognise 4 M10 countersunk screws should you have an unobscured view of the wear plate. Loosen and remove these screws. Using an assembly rod, now loosen the wear plate from the base of the conveying chamber. It may be necessary to cut the old wear plate on one position using an angle grinder. Now remove the wear plate and thoroughly clean the inner walls of the conveying chamber.
7. Now install a new wear plate, tightly fasten the 4 countersunk screws.
8. Grease the pocket wheel shaft, insert the feather key back into the shaft slot. From above, guide the pocket wheel hole above the shaft and push the wheel into its position until the limit stop is reached (ensure that the feather key and the slot are positioned on top of each other).
9. Retighten both of the M12 hexagonal nuts as well as the M24 cap nut.
10. Screw the rotary paddle switch (8) back into the conveying chamber, plug the blow-out flange back into its original position and secure it using both wedges. Carry out all further necessary assembly stages as described above in reverse order.

#### 6.4.6. Replacing the pocket wheel

The conveying output decreases rapidly in the event that the individual edges of the conveying pockets become "round" as a result of wear. Replace the pocket wheel should this occur and proceed as follows.

1. Dismantle the dosing unit and dosing unit housing as described in Points 6.4.1. and 6.4.2..
2. Remove both of the wedges (22) and pull the entire blow-out flange (38) from the shotcrete machine.
3. Take a spanner with a "36" spanner gap and loosen all of the hexagonal bolts belonging to the lid to the conveying chamber (5). Also remove both of the slinging eyelets with which the lid was fastened to the conveying vessel. Remove the lid of the conveying chamber. Also loosen the internal hexagonal bolts that connect the conveying chamber with the lid in the area above the blow-out flange.
4. Unscrew the rotary paddle switch (8) from the conveying chamber.
5. Loosen and remove both of the M (SW 19) hexagonal bolts as well as the cap nuts (SW 36) located on the upper pin end of the pocket wheel. Fasten the detaching device to the pocket wheel using two M12 hexagonal bolts and remove the pocket wheel from the shaft. Pay attention to feather keys that may fall down and collect them.
6. Grease the pocket wheel shaft, insert the feather key back into the shaft slot. From above, guide the pocket wheel hole above the shaft and push the wheel into its position until the limit stop is reached (ensure that the feather key and the slot are positioned on top of each other).
7. Retighten both of the M12 hexagonal nuts as well as the M24 cap nut.
8. Screw the rotary paddle switch (8) back into the conveying chamber, plug the blow-out flange back into its original position and secure it using both wedges. Carry out all further necessary assembly stages as described above in reverse order.

## 7. Disposal

### 7.1. Environmental protection



**Caution.**

**Substances hazardous to water.**

**Such substances can pollute the soil and groundwater or get into the sewage system.**

**When undertaking work on and with the plant, ensure that legal obligations with regard to waste prevention as well as correct recycling / disposal are observed.**

**Substances hazardous to water - e.g. lubricating greases and oils may not pollute the soil or get into the sewage system, particularly when undertaking installation, repair and service works.**

**These substances must be stored, transported, collected and disposed of using suitable containers.**

During the disposal of consumables / replacement materials during the service / decommissioning of the SBS Shotcrete Machine, it is essential that the valid legal regulations are followed.

Substances hazardous to water - e.g. lubricating greases and oils, emulsions and liquids containing petrol may not pollute the soil or get into the sewage system, particularly when undertaking installation, repair and service works.

These substances must be stored, transported, collected and disposed of using suitable containers.

### 7.2. Oil and oil-containing waste, lubricating greases

Oil and oil-containing waste as well as lubricating greases represent a high potential for danger to the environment. For this reason, the disposal of such waste is carried out by special companies.

- Give such waste to the in-house waste department who will forward it on to specialist companies.

### 7.3. Plastics

Used / processed plastics are to be separated as much as possible. Plastics are to be disposed of in accordance with legal requirements.

### 7.4. Metals

Different types of metal are to be separated and disposed of. The disposal must be carried out by an authorised company.

## 7.5. Electrical and electronic waste



### Electrical and electronic waste

Devices that bear this logo or bear this logo on the packaging must be disposed of separately. This devices may not be disposed of together with domestic waste.

You are responsible for ensuring that each piece of electrical and electronic waste is disposed of via the respective body, e.g. via the recycling depot.

## 7.6. Final decommissioning

Check which materials can be passed on for recycling and then arrange for this to be carried out.

## **8. Appendix**

- Declaration of conformity
- Assembly drawings
- Parts list with replacement part recommendation / labelling
- Hydraulic plan + parts list
- Electrical plan + parts list
- Supplier's documentation

## 8.1. Declaration of conformity



## 8.2. Assembly drawings

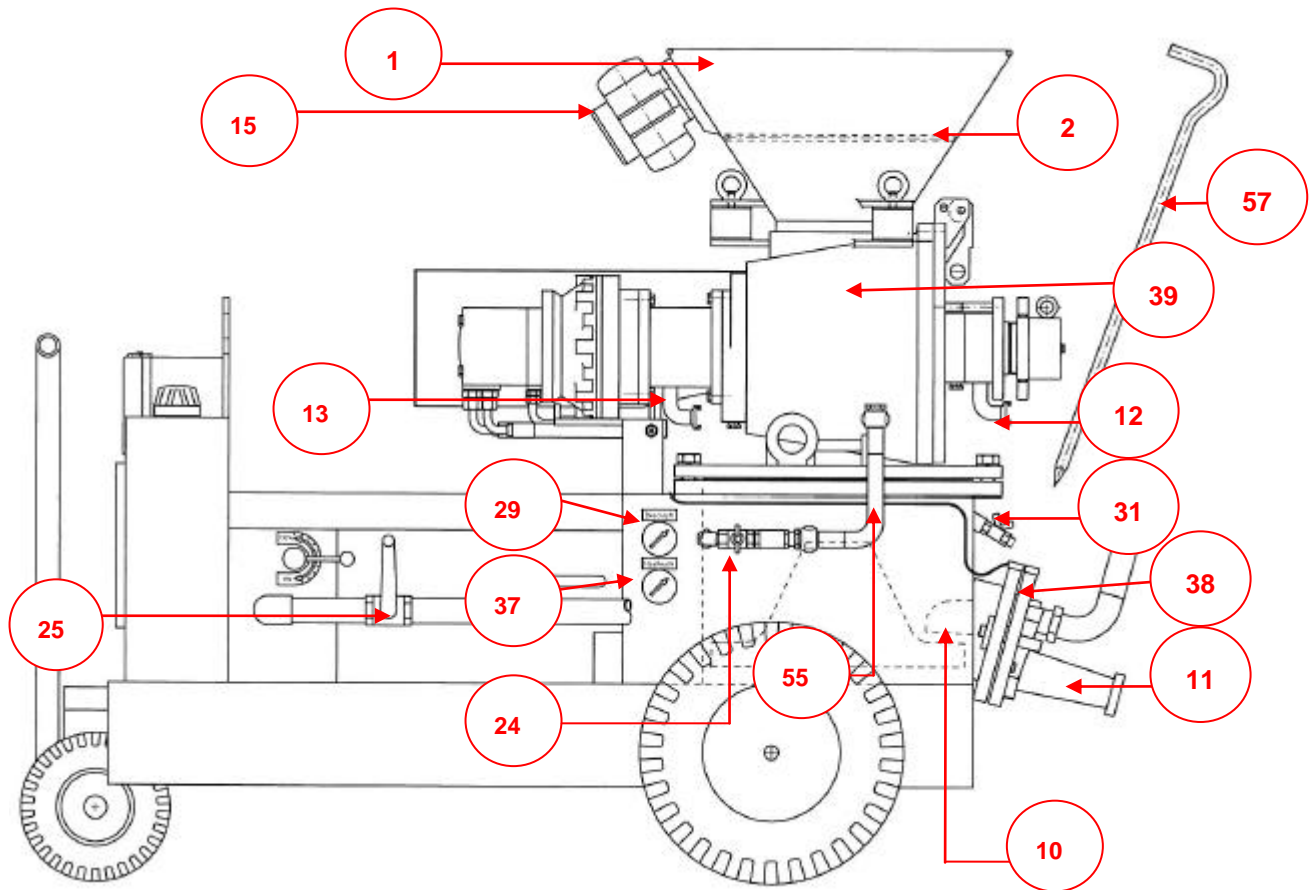

Image 8-1: Overview drawing of the TSN / B1N Shotcrete Machine, side view

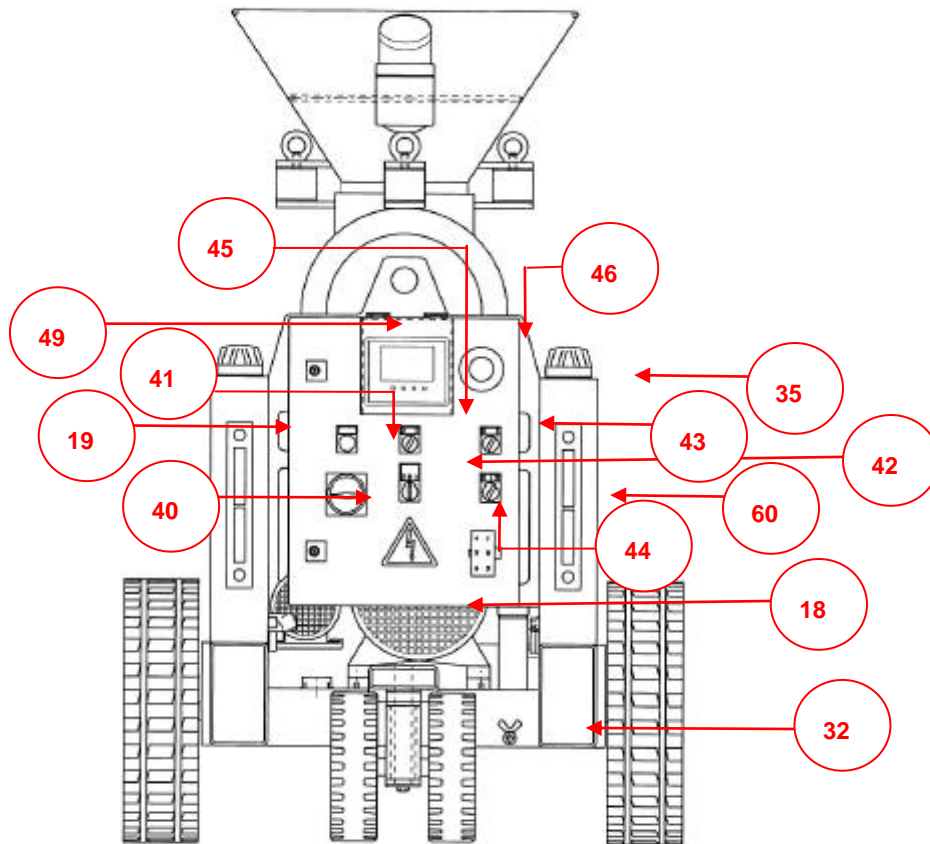

Image 8-2: Overview drawing of the TSN / B1N Shotcrete Machine, rear view

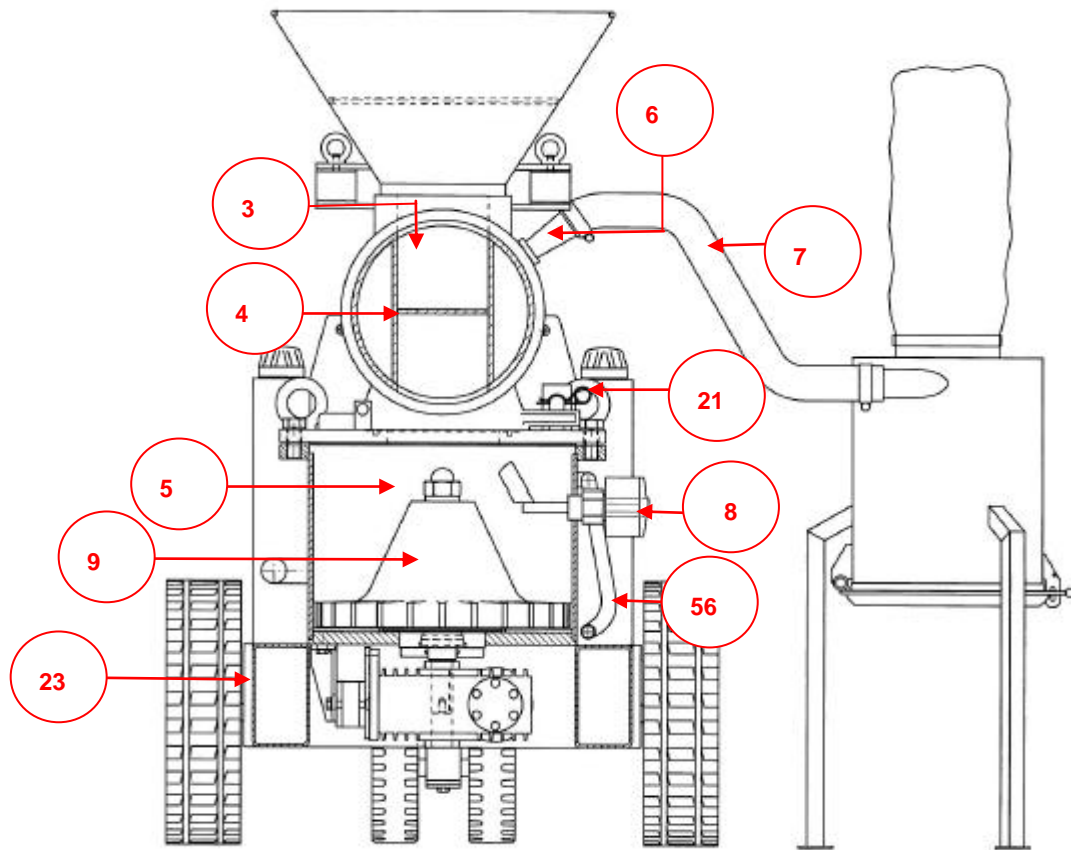

Image 8-3: Overview drawing of the TSN / B1N Shotcrete Machine, front view

The SBS Shotcrete Machine consists of:

1	Material loading hopper	31	Relief valve
2	Loading hopper screen	32	Drainage valve
3	Dosing unit	33	Lubrication points
4	Dosing unit pocket	34	Smooth running agent pump
5	Conveying chamber	35	Smooth running agent tank
6	Exhaust	36	Forelock
7	Exhaust hose	37	Hydraulic manometer
8	Rotary paddle switch	38	Blow-out flange
9	Pocket wheel	39	Dosing unit housing
10	Conveying air injection nozzle	40	Main switch
11	Blow-out nozzle	41	Illuminated push button
12	Water inlet spraying machine	42	Key switch
13	Water outlet	43	"Air" rotary switch
14	Relief vessel	44	"Machine" rotary switch
15	Vibrator	45	"Vibrator" rotary switch
16	Remote control	46	Emergency stop switch
17	Control panel	47	Coupler base
18	Electric motor	48	32 A CEE Plug
19	Oil fill level display	49	Display
20	Wedge (large)	50	"Air" rotary switch remote control
21	Forelock (large)	51	"Machine" rotary switch remote control
22	Wedges (small)	52	Emergency stop remote control
23	Hydraulic tank	53	Remote control plug
24	1/2" ball valve	54	Dosing equipment
25	Ball valve for conveying air	55	Blow-out equipment
26	Filter bag	56	Compensation line
27	Conveying quantity setting	57	Tension lever
28	Smooth running agent fill level display	58	Filter bag plastic cover
29	Compressed air manometer	59	Dummy plug
30	Adjustment device	60	Fill level display

### 8.3. Parts list

Please find the part list at the separate documentation!

8.4. Hydraulic plan

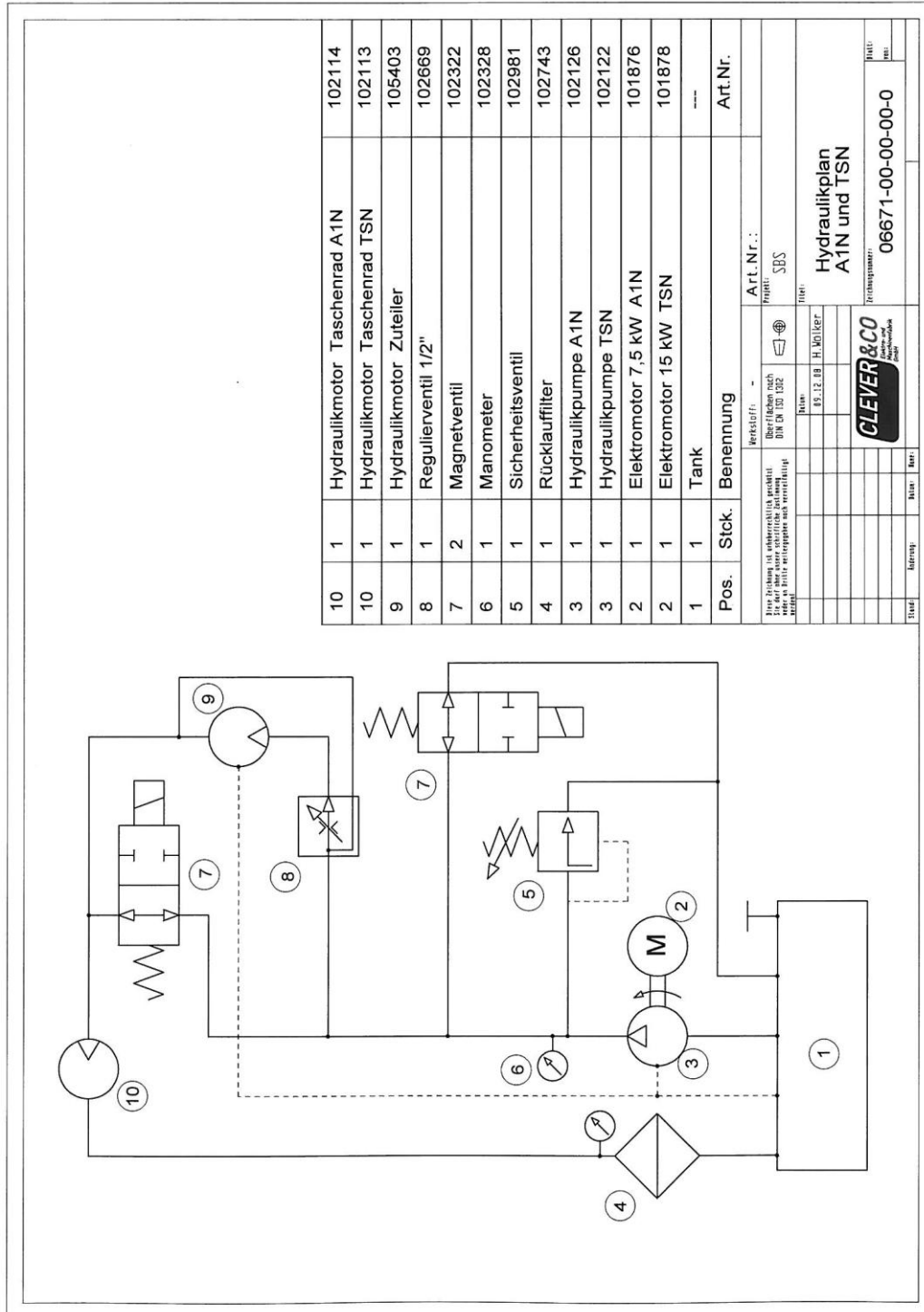

## 8.5. Electrical plan