



USE AND MAINTENANCE MANUAL



GIOTTO MONO

IS16/02 - 561379



Serial number

Year

<input type="text"/>	<input type="text"/>	<input type="text"/>	<input type="text"/>	<input type="text"/>	<input type="text"/>	<input type="text"/>	<input type="text"/>	<input type="text"/>	<input type="text"/>
----------------------	----------------------	----------------------	----------------------	----------------------	----------------------	----------------------	----------------------	----------------------	----------------------

INDEX

1	- CE DECLARATION	5
1.1	CE DECLARATION OF CONFORMITY	5
2	- GENERAL INFORMATION	7
2.1	IMPORTANCE OF THE MANUAL.....	7
2.2	ABBREVIATIONS.....	7
2.3	INFORMATION FOR CONSULTING THE MANUAL.....	7
2.4	DESCRIPTION OF THE SYMBOLS.....	7
2.5	STATUS "MACHINE OFF"	8
2.6	GENERAL AND CONTACT INFORMATION	8
3	- TECHNICAL DESCRIPTION.....	9
3.1	NAME OF MACHINE	9
3.2	DIMENSIONS OF MACHINE.....	10
3.3	TECHNICAL DATA.....	10
3.4	INTENDED USES	10
3.5	PRODUCTS USED FOR PROCESSING.....	11
3.6	NAME OF COMPONENTS.....	12
4	- TRANSPORT AND HANDLING	13
4.1	TRANSPORT	13
4.2	LIFTING	13
5	- INSTALLATION.....	15
5.1	PLACEMENT	15
5.2	HOSES.....	16
5.3	COUPLINGS.....	16
5.4	CONNECTIONS.....	17
6	- SAFETY	21
6.1	SAFETY DEVICES USED.....	21
6.2	SAFETY SIGNALS	22
LABEL	22	
DESCRIPTION	22
6.3	PERSONAL PROTECTIVE EQUIPMENT	23
MANDATORY SIGNS	23
DESCRIPTION	23
6.4	RESIDUE RISKS.....	24
6.5	SAFETY WARNINGS	24
7	- USE AND OPERATION.....	25
7.1	OPERATING PRINCIPLE.....	25
7.2	PUMPABLE MATERIALS	25

7.3	CHECKS BEFORE SWITCH-ON	26
7.4	CONTROLS	28
7.5	MACHINE SWITCH-ON.....	29
7.6	CLEANING AND END OF WORK.....	31
7.7	REPLACING THE PUMPING UNIT.....	33
7.8	IMPORTANT WARNINGS	34
8	- MAINTENANCE.....	37
8.1	OPERATOR RESPONSIBILITY	37
8.2	QUALIFIED PERSONNEL RESPONSIBILITY.....	37
9	- DEMOLITION	39
9.1	MAIN WARNINGS	39
10	- TROUBLESHOOTING	41
10.1	MATERIAL DOES NOT COME OUT OF THE GUN	41
10.2	BLOCKING THE PUMP.....	42
10.3	FUSES/OVERLOAD CUTOUT TRIPPING	42
10.4	OTHER PROBLEMS	42
10.5	OPERATOR INTERVENTION	43
11	- OPERATOR RESPONSIBILITY	45
11.1	RESPONSIBILITY	45
11.2	WARRANTY.....	45



1 - CE DECLARATION

1.1 CE DECLARATION OF CONFORMITY

**Dichiarazione CE di conformità - EC declaration of Conformity - EG – Konformitätserklärung -
Déclaration CE de conformité - Declaración de Conformidad CE - Declaração CE de conformidade**

Il fabbricante - *The manufacturer* - Le fabricant - *Der Hersteller* - El fabricante - *O fabricante*

TURBOSOL
PRODUZIONE S.p.A.
Via A. Volta, 1
31030 Pero di Breda
TREVISO – ITALIA

dichiara che la seguente macchina:
declares that the machinery:
déclare que la machine:
erklärt, dass die Maschine:
declara que la máquina:
declara que a máquina:

Intonácatrice
Plaster sprayer
Machine à projeter les enduits
Putzmaschine
Enlucidora
Rebocadora

Modello - *Model* - Modèle - *Modell* - Modelo - *Modelo* **MODELLO**
Versione - *Version* - *Version* - *Version* - *Version* - *Versión* - *Versão* **VERSIONE**
Matricola numero - *Serial number* - Numéro de matricule -
Seriennummer - Número de matrícula - *Número de matrícula* **XXX.XXX**
Anno di fabbricazione - *Year of manufacture* - Année de fabrication -
Herstellungsjahr - Año de fabricación - *Ano de fabrico* **ANNO**

è conforme alle disposizioni della direttiva 98/37/CE e alle disposizioni nazionali di attuazione;
è anche conforme alle disposizioni delle seguenti direttive europee: 2000/14/CE, 2006/95/CE, 2004/108/CE;
è conforme alle disposizioni delle seguenti norme armonizzate: EN 12100-1/2:2005, EN 294:1993, EN 60204:2006.

fulfils all the relevant provisions of the Directive 98/37/EC;
also fulfils all the relevant provisions of the following European Directives: 2000/14/EC, 2006/95/EC, 2004/108/EC;
fulfils the provisions of the following harmonised standards: EN 12100-1/2:2005, EN 294:1993, EN 60204:2006.

est conforme aux dispositions de la directive 98/37/CE;
est également conforme aux dispositions des directives européennes suivantes: 2000/14/CE, 2006/95/CE, 2004/108/CE;
est conforme aux dispositions des normes harmonisées suivantes: EN 12100-1/2:2005, EN 294:1993, EN 60204:2006.

den Bestimmungen der Richtlinie 98/37/EG;
ebenso den Bestimmungen der folgenden europäischen Richtlinien entspricht: 2000/14/EG, 2006/95/EG, 2004/108/EG;
den Bestimmungen der folgenden harmonisierten Normen entspricht: EN 12100-1/2:2005, EN 294:1993,
EN 60204:2006.

es conforme a las disposiciones de la directiva 98/37/CE ;
también es conforme a las disposiciones de las siguientes directivas europeas: 2000/14/CE, 2006/95/CE, 2004/108/CE;
es conforme a las disposiciones de las siguientes normativas armonizadas: EN 12100-1/2:2005, EN 294:1993,
EN 60204:2006.

é conforme às disposições da directiva 98/37/CE;
também é conforme às disposições das seguintes directivas europeias: 2000/14/CE, 2006/95/CE, 2004/108/CE;
é conforme às disposições das seguintes normas harmonizadas: EN 12100-1/2:2005, EN 294:1993, EN 60204:2006.



An original copy of the CE Declaration of Conformity is supplied separately from the manual.





2 - GENERAL INFORMATION

2.1 IMPORTANCE OF THE MANUAL

This "Use and Maintenance Manual" has been drawn up following the guidelines envisioned in the relevant European Directives in order to guarantee simple and full understanding of the subjects by the operators authorised to operate and perform maintenance on the machine in question. The manufacturer has prepared this manual with the greatest care. However, should any operators find any part of the manual difficult to understand, they should contact the manufacturer immediately and request explanations and/or further information in order to avoid misunderstandings that might compromise the user's safety. Before using the machine, authorised operators must read and understand this "Use and Maintenance Manual" in every part and strictly follow the Standards herein, in order to ensure their own safety and that of others, to make the machine work at its full potential and to ensure a long-lasting and efficient service life to all the machine parts. This manual should be safely stored and kept close to the machine at all times for immediate consultation by operators.

Only specifically trained and authorised staff can operate and perform maintenance on the machine.

Operators must follow all the instructions regarding the prevention of accidents and the regulations on workplace safety in force in the country of use.

The Manufacturer shall not be responsible for any damages resulting from changes made arbitrarily to the machine.

Users are advised to take note of the machine's serial number; it must be presented along with every request for technical assistance or for spare parts, and will facilitate processing such requests.

This manual reflects the latest information available at the time of marketing the appliance and should not be considered inadequate only because it may be successively updated on the basis of newly acquired information.

Reprinting or reproducing this manual, in whole or in part, is not allowed unless authorized by ourselves in writing.

THE MANUFACTURER DECLINES ANY RESPONSIBILITY FOR DAMAGES TO PERSONS, ANIMALS OR PROPERTY CAUSED BY FAILURE TO OBSERVE THE STANDARDS AND RECOMMENDATIONS CONTAINED HEREIN.

2.2 ABBREVIATIONS

ca.	around	min	minutes
cap.	chapter	N.	number
DPI	device of individual protection	pag.	page
DX	right	par.	paragraph
h	times	pos.	position
EN	European Norm	RIF.	reference
Es.	example	s	second
FIG.	figure	SX	left
max.	maximum	TAB.	table
min.	minimum	v.	see

TAB.01

2.3 INFORMATION FOR CONSULTING THE MANUAL

Boldface:

Highlights important parts in the text.

2.4 DESCRIPTION OF THE SYMBOLS

Information and recommendations that are particularly important are indicated in this manual by the following symbols:



ATTENTION: *this symbol indicates safety regulations regarding the operator.*



PRECAUTION: *this symbol indicates the possibility of causing damage to the machine and/or its parts.*



IMPORTANT NOTE: *this symbol supplies useful information.*



2.5 STATUS "MACHINE OFF"

Before performing any type of maintenance and/or regulation on the machine, it is mandatory to isolate the electric power supply. Disconnect the electric cable, make sure that the machine is effectively off, make sure that there is no residual pressure in the piping (On trampling the pipes must go limp) and that the line manometer indicates zero bar.

2.6 GENERAL AND CONTACT INFORMATION

The ready/mixed plastering machine can be supplied in different set-ups and with different accessories, therefore it is not said that all components described in this manual are mounted on your machine.

The Customer Service department of Turbosol Produzione S.p.A. will be glad to provide any information you may need.



Turbosol Produzione S.p.A.

Via Volta, 1
31030 Pero di Breda di Piave (TV) - ITALIA

Tel. +39 - 0422 - 90.2.51
Fax +39 - 0422 - 90.44.08
website: www.turbosol.it
e-mail: info@turbosol.it

TURBOSOL MACHINES

They are the result of years of experience and constant research. The "know how" acquired in this way, along with great attention to quality, constitutes the fundamental guarantee for the manufacturing of machines with long duration, great reliability and reduced management costs.

MAINTENANCE AND CARE

Proper maintenance and care are essential for the machine to work as designed. It is therefore extremely important that users respect the recommended maintenance intervals and carry out any maintenance required, both to keep the machine in perfect running order and to preserve the validity of the warranty.

SAFETY

All service staff must be informed of the Safety Standards. The general Standards relative to safety and accident prevention envisioned by local legislation must also be complied with.

OPERATOR TRAINING

The operator must receive specific training regarding the operations to be carried out. Turbosol periodically carries out training courses, also on specific request of the customer.

TURBOSOL SERVICE

Please contact your TURBOSOL dealer for any information regarding machine malfunctions or requests for spare parts.

Turbosol Produzione S.p.A. reserves the right to make any technical modification for machine improvement, even if not contemplated in this manual. Some drawings and representations may be indicative.



3 - TECHNICAL DESCRIPTION

3.1 NAME OF MACHINE

CE mark plate

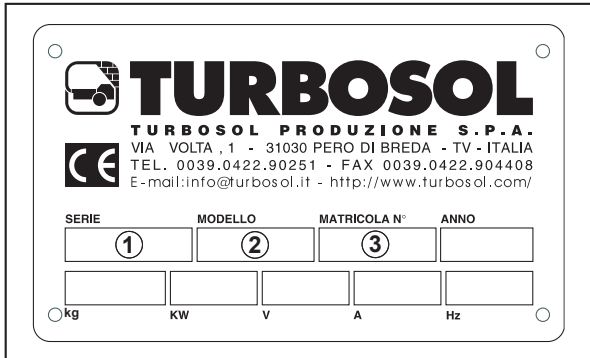

FIG.01

The machine's series (1), model (2) and serial number (3) are engraved on the nameplate, as well as its power rating. The meaning of the symbols used are as follows.

(1) = Machine series:

(2) = Machine model:

(3) = Machine serial number.

Position of the CE mark plate

The CE mark plate (FIG. 02-REF. 1) is affixed to the mixer chamber.

Position of the machine serial number

The machine's serial number (FIG. 02-REF. 2) is punched onto the mixer chamber as well as on the nameplate.

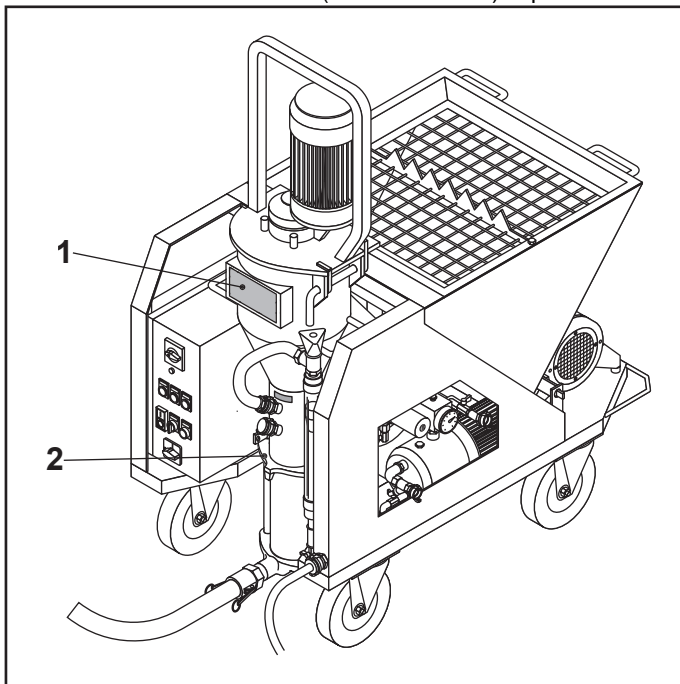

FIG.02



3.2 DIMENSIONS OF MACHINE

The following are the machine's overall dimensions and gross weight (in working conditions).

LENGTH	WIDTH	HEIGHT	WEIGHT
1.150 mm	650 mm	1.470 mm	250 kg

TAB.02

3.3 TECHNICAL DATA

Type of power supply	-	Single-phase
Power voltage	V	230
Power supply frequency	Hz	50
Control circuit power supply	V	24 AC
Installed power	kW	4.37
Pneumatic circuit set pressure	bar	2
Hydraulic circuit pressure reducer set pressure	bar	2
Maximum granulometry processable (with D5 2.5 ECO pump)	mm	5
Delivery distance (approximate)	m	15
Hopper capacity	l	110
Permissible environmental temperature	°C	0° ÷ 35°
Guaranteed sound power level LwA	dB	101*
Guaranteed sound pressure level LpA	dB	78

Mortar pump gear motor			
Power		kW	
		3	
Performance	1°	l/min-rpm	
	2°		12-225
	3°		14.5-270
		18-300	

Dispenser gear motor			
Power		kW	
		0.25	
Speed	1°	rpm	
	2°		6
	3°		7.5
		9	

Water pump		
Power		kW
		0.6
Flow rate		l/min
		45
Head		m
		43
Pressure switch set pressure		bar
		1.5

Compressor		
Power		kW
		0.52
Flow rate		l/min
		210
Maximum pressure		bar
		4

TAB.03

* The operator must use Individual Protection Devices (IPD) for hearing.

3.4 INTENDED USES

The machine has been designed and built for the following use:

FIELD OF USE: construction sector.

DECLARED USE: conveying and spraying ready-mixed plasters.



3.5 PRODUCTS USED FOR PROCESSING

Cement or gypsum based dry ready-mixed products. GIOTTO is not suitable for processing traditional mortars.



3.6 NAME OF COMPONENTS

FIG.03 shows the illustrations and names of the main components that make up the machine.

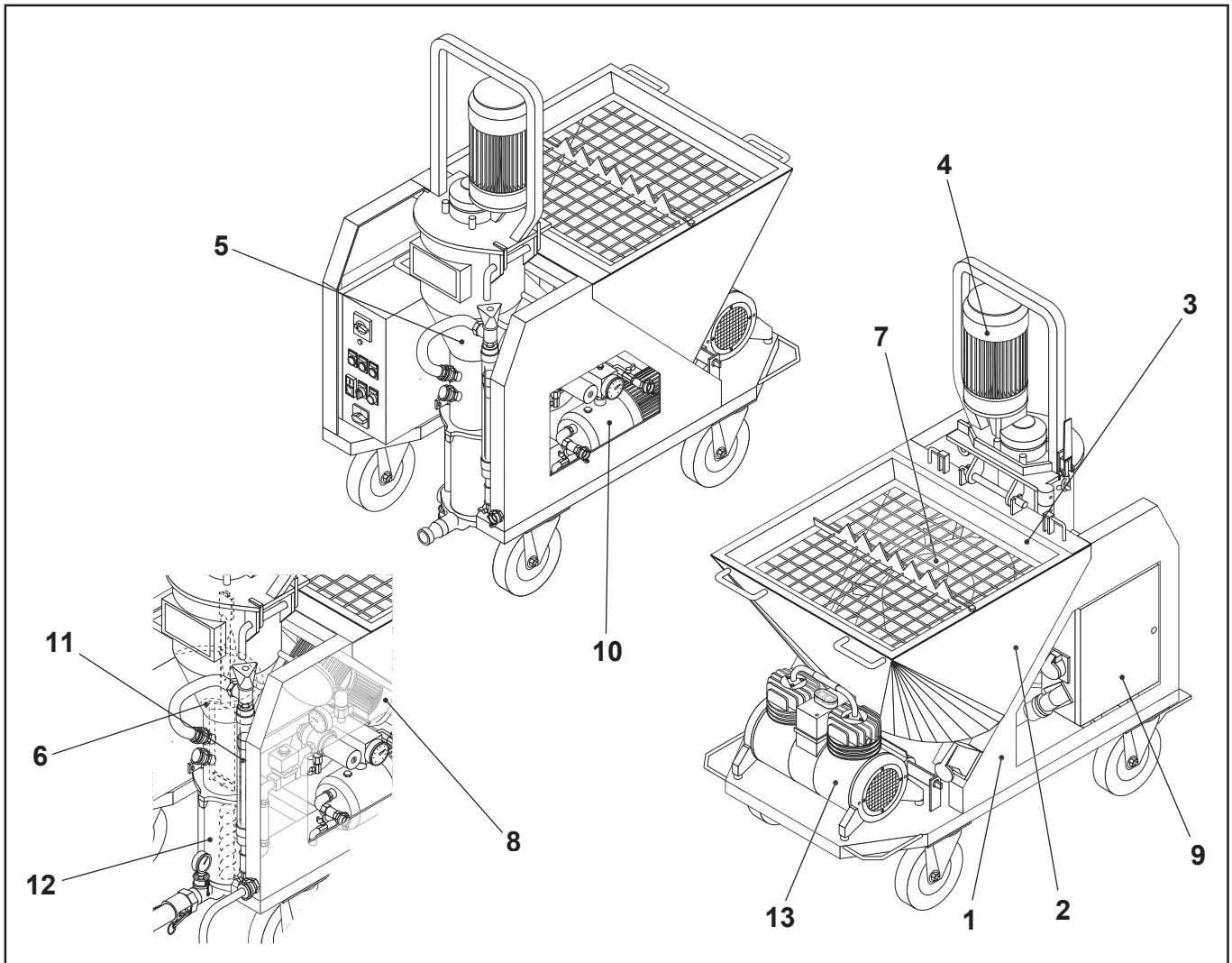

FIG.03

KEY:

- 1) Frame
- 2) Hopper
- 3) Protection grid
- 4) Main gear motor
- 5) Mixing chamber
- 6) Mixer
- 7) Dispenser
- 8) Dispenser gear motor
- 9) Electromechanical control board
- 10) Water pump
- 11) Flow meter
- 12) Pump (stator + screw)
- 13) Compressor



4 - TRANSPORT AND HANDLING

4.1 TRANSPORT

GIOTTO has four pivoting wheels, one with a brake, for moving inside the work area; the frame/hopper has two mobile handles (FIG.04 REF.1) that facilitate manual lifting.

GIOTTO can be dismantled into 4 parts and transported separately:

- gear motor-mixer
- mixing chamber unit
- compressor
- frame with hopper

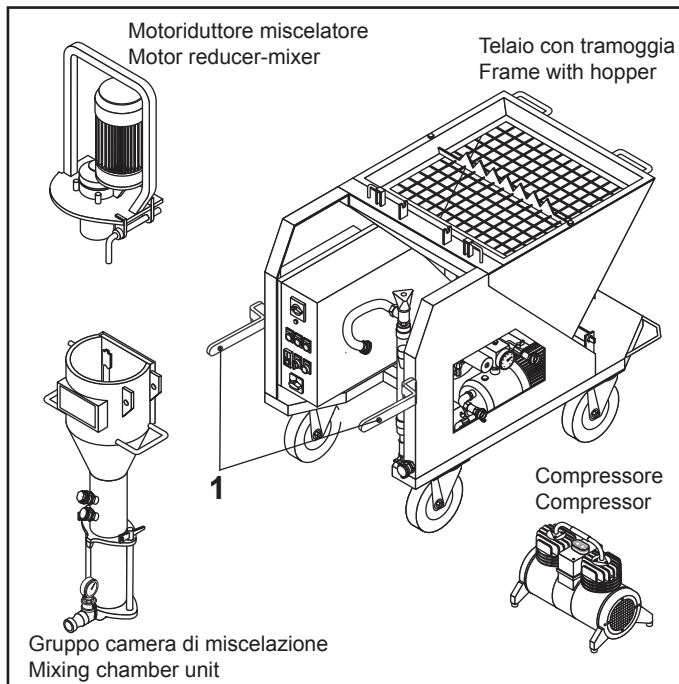

FIG.04

GIOTTO cannot be towed on the road. GIOTTO must be loaded, arranged and transported on a vehicle in compliance with the highway code in force.

4.2 LIFTING



GIOTTO cannot be hoisted with lifting means such as, for example, a crane, as it is not equipped with suitable hooks.





5 - INSTALLATION

5.1 PLACEMENT

Place the machine on a horizontal plane; the maximum allowed longitudinal and transversal slope is 5° (FIG.05).

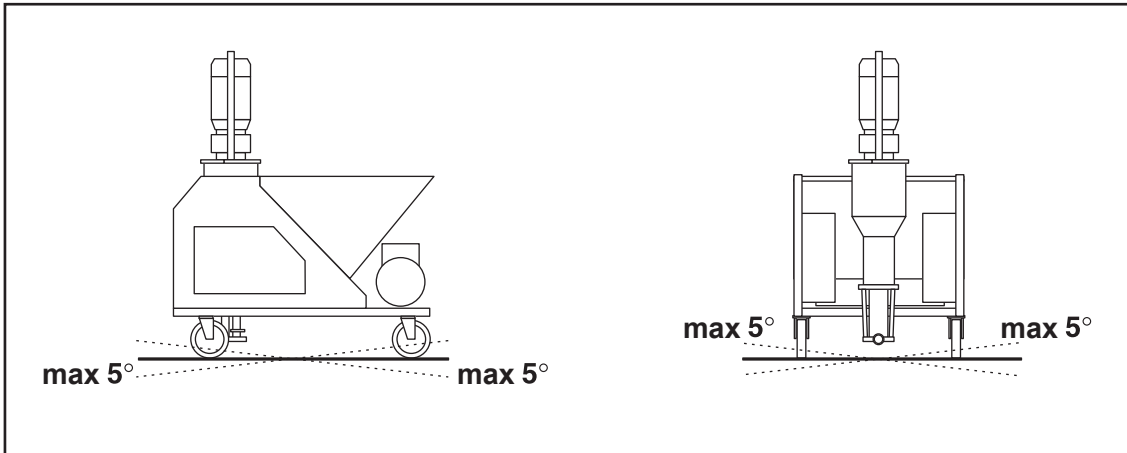

FIG.05

Before starting, make sure the wheel with brake is locked.



There must be a minimum clear floor space around the machine (FIG.06), free from any obstructions and with a walkway without any holes or dangerous protrusions.

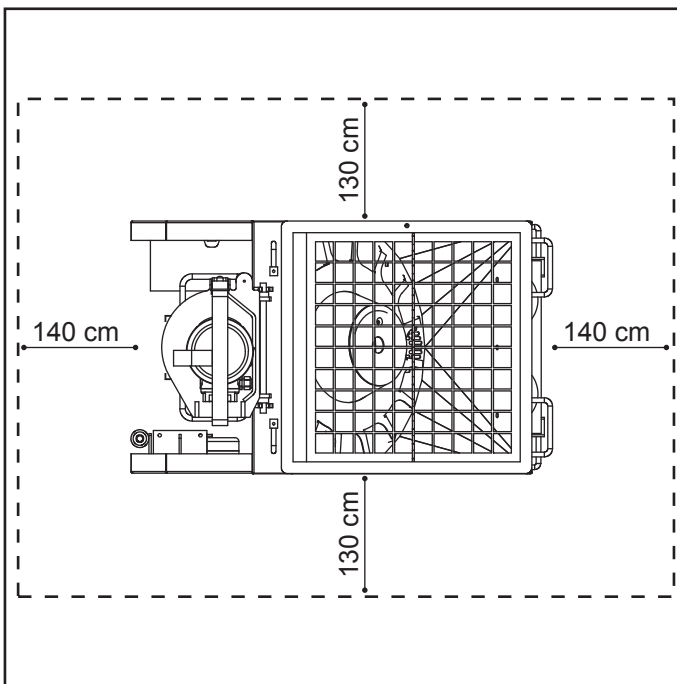

FIG.06



5.2 HOSES

Lay hoses optimising their length (transport and wear times are reduced), while making sure they are in good condition.



Only use original hoses and couplings. The hoses must be connected by TURBOSOL PRODUZIONE S.p.A. or by companies expressly authorised by the former. In no case shall TURBOSOL PRODUZIONE S.p.A. be liable for damage to persons or things caused by the use of non-original hoses or couplings.

5.3 COUPLINGS



Check couplings are always effective and clean.

Camlock fittings

Connect the hoses ensuring the presence of rubber gaskets (FIG.07-REF.1); fully tighten the levers (FIG.07-REF.2). Always connect the longer hoses to the machine and the shorter ones to the gun.

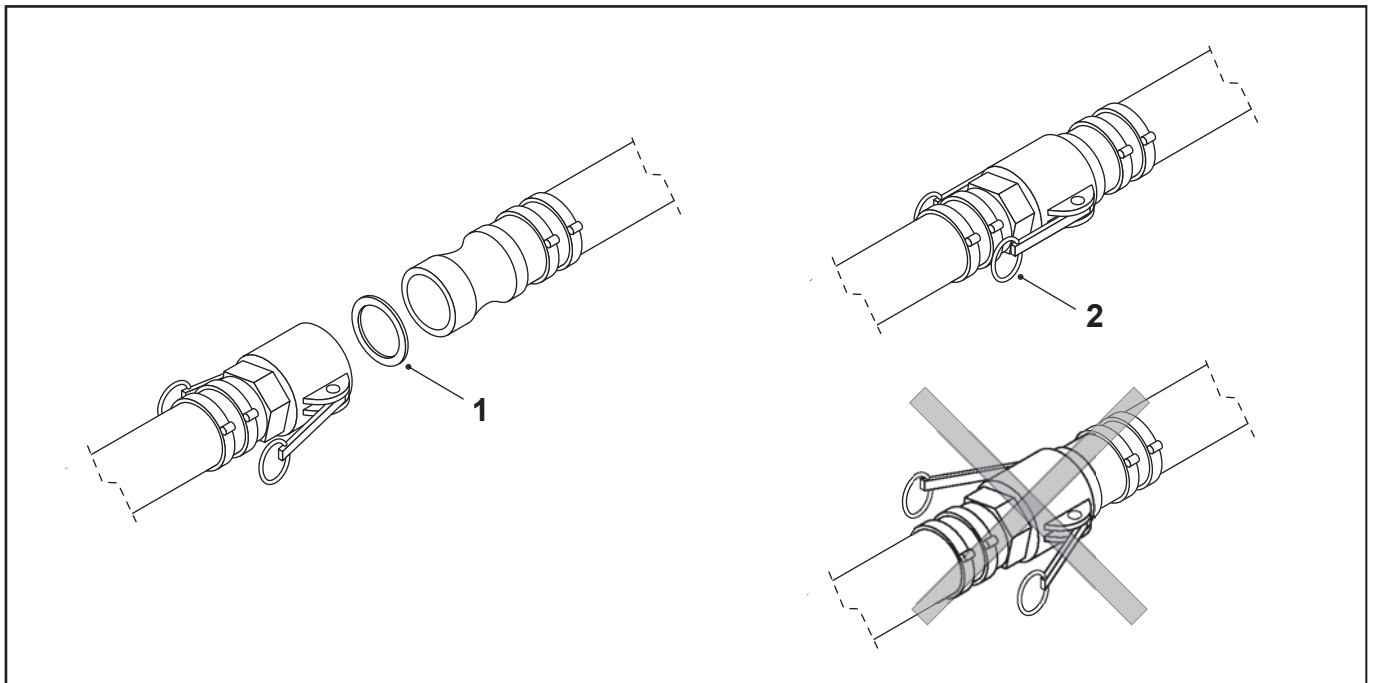

FIG.07



5.4 CONNECTIONS

Electrical connection

- Connect the mixer's motor gear power plug (FIG.08-REF.1) and the compressor's power plug to the socket (FIG.08-REF.2).

Before connecting GIOTTO to the construction site's electrical control board, make sure it complies with the current safety regulations and directives.

The construction site's electrical control board must comply with the regulations in force and have:

- enough power to supply the machine,
- adequate earthing,
- adequate fuses,
- highly-sensitive circuit breaker.

Connect GIOTTO to the construction site's electrical control board with a H07RN-F marked neoprene coated cable (2P+T), with a minimum section of:

2.5 mm² for distances up to 20 m

4 mm² for distances up to 35 m

6 mm² for distances up to 50 m

Using an electrical cable with inadequate section compromises machine operation.

- Connect the power cable to the socket (FIG.08-REF.3).

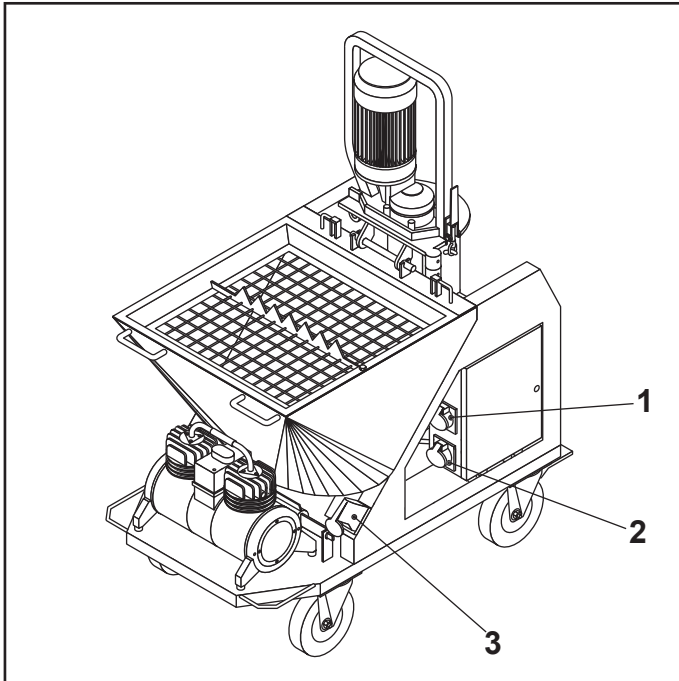

FIG.08

Other connections

- Connect the material hoses (FIG. 09-REF.1) to the delivery flange (FIG. 09-REF.2).
- Connect the water hose to the quick coupling (FIG. 09-REF.3) on the mixing chamber. It is usually connected to the top connection.
- Connect the compressor's air hose (FIG. 10-REF.1) to the compressor.
- Connect the gun's air hose to the connection (FIG. 10-REF.2).
- Connect the gun (FIG. 10-REF.3) to the ends of the material hose (FIG. 10-REF.4) and air hose (FIG. 10-REF.5).

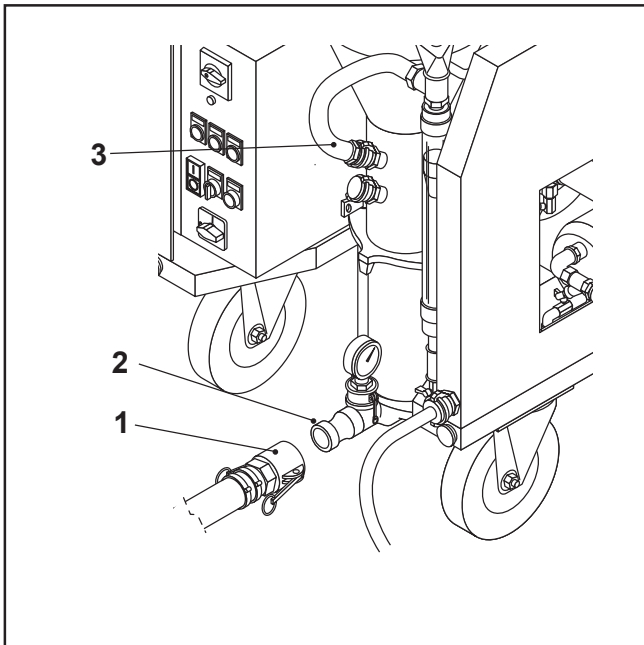

FIG.09

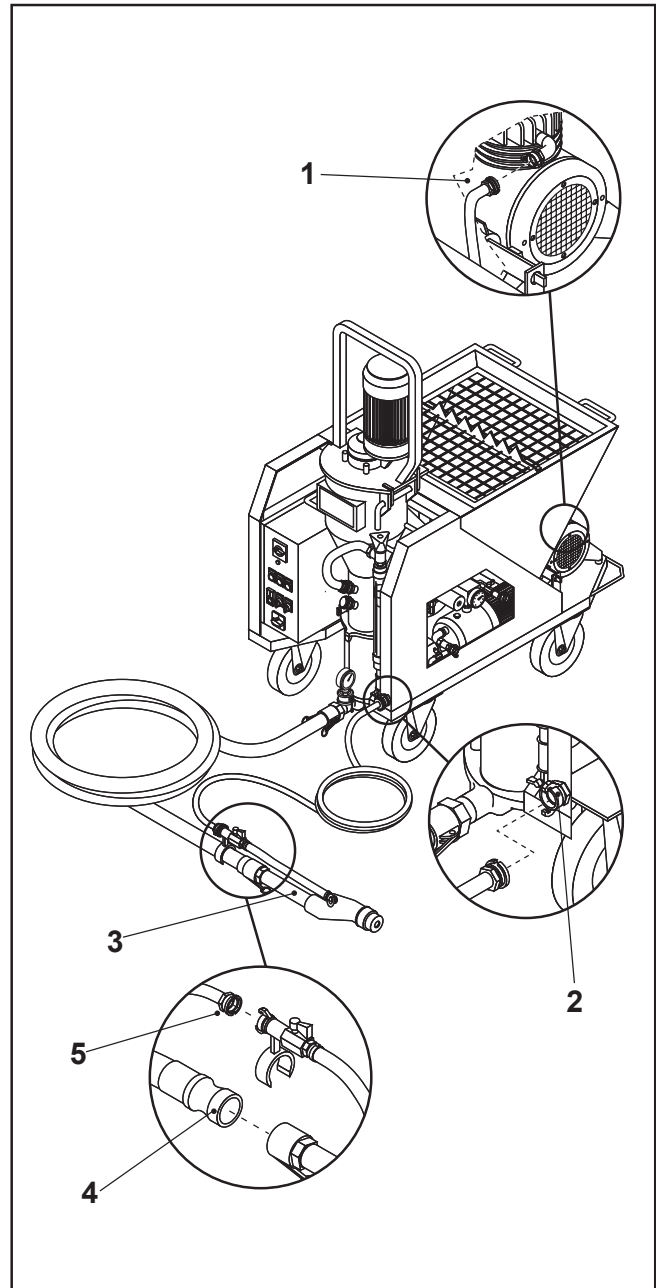

FIG.10

- Connect the water supply hose to the quick coupling of the water pump (FIG.11-REF.1).

When connecting the water pump to a container for the first time (or, however, after the hydraulic system is drained or a prolonged stop), the pump must be primed in advance, otherwise the mechanical seal will be damaged.

To check that the pump is primed, water must come out when the cock is opened (FIG.11-REF.2).

The water flow used can differ from the above indications in relation to the length of the conveying hose line, wear of the pump (screw and stator), and experience of the user.

The water entering the water pump must be clear and free of impurities. If the water network does not provide the required water flow, use a 200 litre container with compensation function. The container must have a cock with float, it must be in a raised position with respect to the stationing plane of the machine and the water draught must be at least 50 cm above the connection (FIG.11-REF.1).

Draw water from it through the hose with filter (supplied).

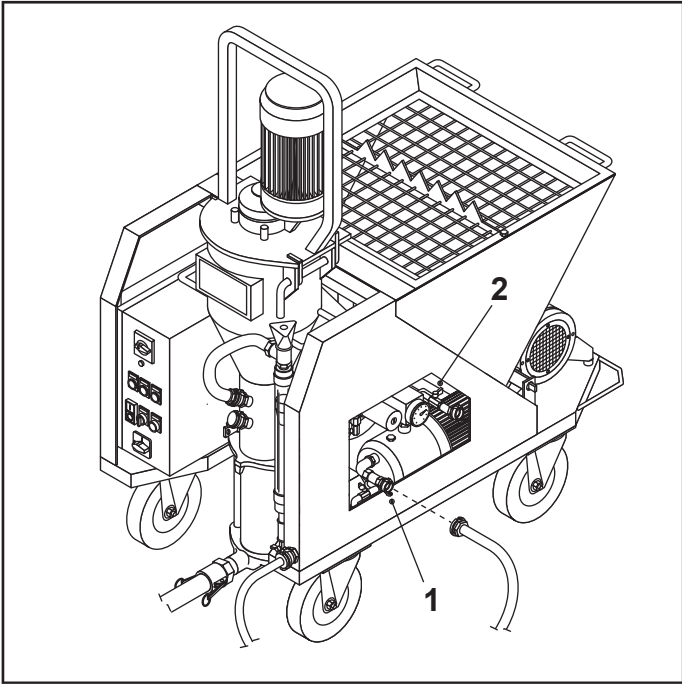

FIG.11





6 - SAFETY

6.1 SAFETY DEVICES USED

HOPPER PROTECTION GRID

Fixed protection screwed. Avoid contact with the moving parts inside the hopper.

MORTAR PUMP GEAR MOTOR MOBILE SUPPORT

Movable protection interlocked. The mortar pump stops when the support is opened. To restart the mortar pump you must reactivate the function.

PNEUMATIC SYSTEM PRESSURE RELIEF VALVE

Avoid circuit overpressure.



TAMPERING WITH, EXCLUDING AND/OR REMOVING ANY OF THE SAFETY DEVICES ON THE MACHINE IS STRICTLY PROHIBITED.



REPLACING ANY SAFETY DEVICE OR ONE OF ITS COMPONENTS WITH NON-ORIGINAL SPARE PARTS IS STRICTLY PROHIBITED.



IT IS COMPULSORY TO CONSTANTLY MAKE SURE THAT ALL SAFETY DEVICES INSTALLED ON THE MACHINE OPERATE PROPERLY.





IT IS COMPULSORY TO IMMEDIATELY REPLACE ANY MALFUNCTIONING AND/OR DAMAGED SAFETY DEVICES.



6.2 SAFETY SIGNALS

The safety signals consist in adhesive labels applied to the machine.

REF.	LABEL	DESCRIPTION
A		Danger electric shocks.
B		It is mandatory to read the instruction manual before starting to operate.

TAB.04



It is compulsory to always keep the safety signals clean to guarantee good visibility.



It is compulsory to replace the deteriorated safety signals, requesting them from the manufacturer.



It is strictly forbidden to remove or damage the safety signals applied on the machine.

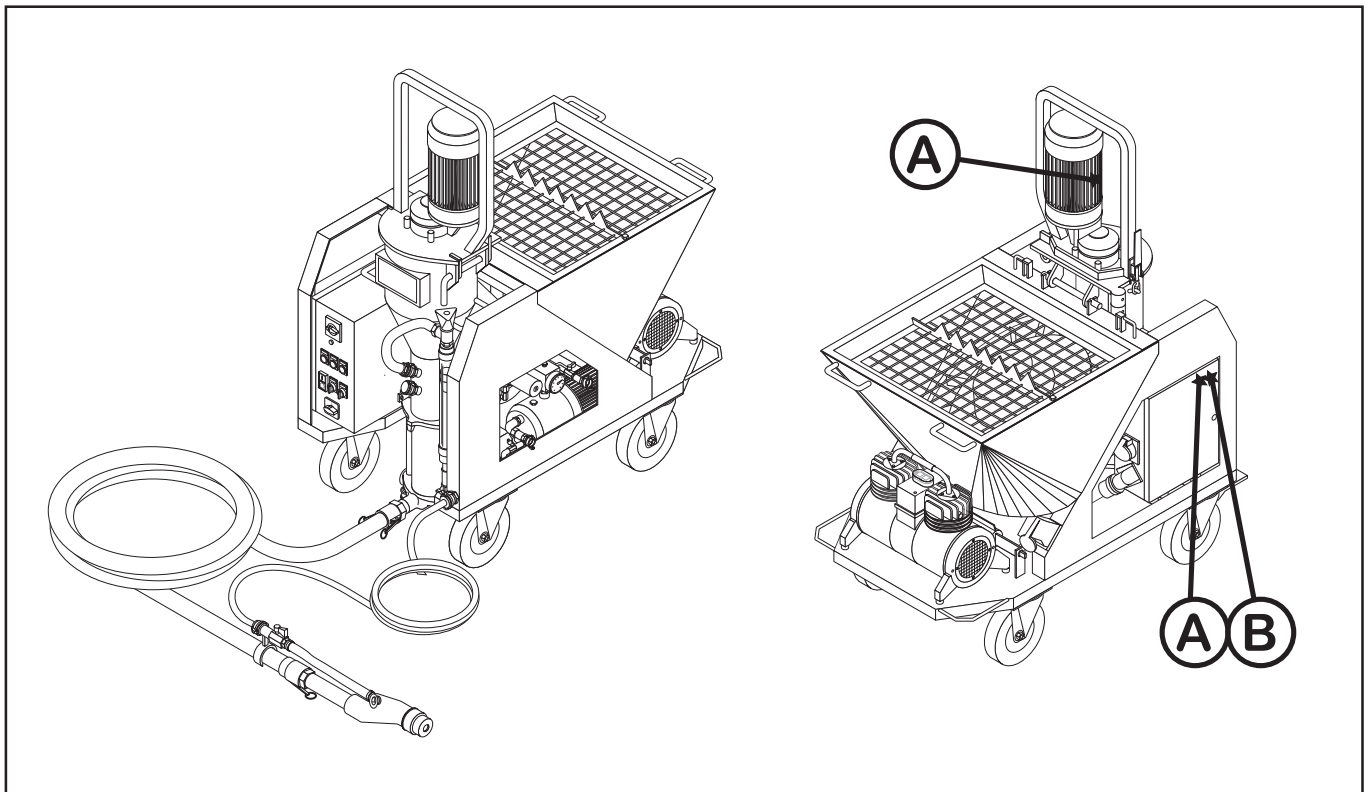

FIG.14







6.3 PERSONAL PROTECTIVE EQUIPMENT

Using personal protective equipment is compulsory in respecting the standards on health and safety at the workplace in force in the country where the machine is used.

Employers, managers and operators in charge must know and apply said standards.



USING THE PERSONAL PROTECTIVE EQUIPMENT INDICATED BY THE MANUFACTURER IS COMPULSORY (TAB.05).

MANDATORY SIGNS	DESCRIPTION
	IT IS MANDATORY TO PROTECT THE EYES.
	IT IS MANDATORY TO PROTECT HEARING.
	IT IS MANDATORY TO PROTECT THE HANDS.
	IT IS MANDATORY TO PROTECT THE FEET.

TAB.05



6.4 RESIDUE RISKS

Following the instructions and recommendations contained in this manual allows you to use the machine properly and reduce residual risks.

IN PARTICULAR:

Read the use and maintenance manual before commissioning the machine.

The operators at the machine and in the material unloading area must be trained to properly carry out the operations contained in this manual.

Carry out all maintenance operations in "machine off" status.

PARTS UNDER PRESSURE:

Make sure and guarantee that the hose is structurally intact.

Make sure all of the hoses' quick couplings and joints are tightened properly.

Do not disconnect the fittings when the hose is under pressure.

HOT PARTS:

Do not touch the gear motor, compressor or water pump when GIOTTO is in operation or within an hour after it has been switched off.

MOVING PARTS:

Do not put foreign objects through the protection grid when the dispenser is moving.

Do not use the machine without the delivery flange and pump properly installed.

Do not open the gear motor support while the machine is in operation.

Do not use the machine without the protection grid or sleeve properly assembled and fitted.

ELECTRICAL PARTS:

Never operate with the electrical control board open.

Do not direct intense water jets on the electrical control board or on the electrical sockets.

6.5 SAFETY WARNINGS

- The machine must never operate if the hose is not connected to the delivery flange and to the spray gun.
- Follow the instructions on how to position the machine before starting it up.
- Check the state of wear of the hoses and related joints daily, as there is a danger of explosion, projected material and cutting should the hoses break or disconnect from the joints.
- Do not insert objects through the protection grid with the power supply connected, risk of severe impact.
- Do not use the machine with flammable materials or in explosive zones.
- Use extreme caution when walking near the transport piping as there may be sudden movements, risk of impacts and tripping.
- Should the material get clogged inside the transport piping, follow the relevant instructions in the following manual.
- The machine operator must pay constant attention to what happens in the work area so as to be able to intervene promptly, and in the event of an emergency stop the machine.



7 - USE AND OPERATION

7.1 OPERATING PRINCIPLE

The bags of dry ready-mix are placed on the protection grid, which is fitted with a bag breaker. When the bag is broken, the powder falls into the hopper.

The dispenser conveys the material from the hopper to the mixing chamber, where the mixer mixes it with water. The water output is regulated by a cock above the flow meter; the output is displayed in the flow meter graduated scale.

The pump connected to the mixer sends the mixture to the gun via the hose.

The compressed air from the compressor is also conveyed to the gun; the mixture (formed by air and mixture) comes out from the gun in the form of a jet. The angular width of the jet can be regulated by axial displacement of the nozzle (FIG.15-REF.1) by the air inside the gun and/or by replacing the deflector (FIG.15-REF.2).

The gun is fitted with a cock (FIG.15-REF.3) that intercepts the air flow; its opening and closing controls the machine start and stop.

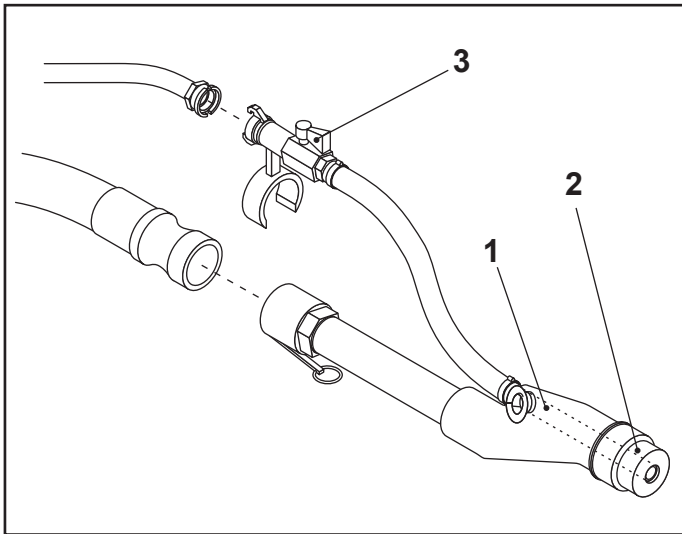

FIG.15

7.2 PUMPABLE MATERIALS

GIOTTO processes dry cement or gypsum based ready-mixes with aggregate size compatible with the pump.

The performance and quality of the processed product depends on a combination of the following factors:

- type of ready-mix
- quality of the ready-mix
- water percentage in the mix
- length of hose
- spray gun configuration (type of deflector, air nozzle position, etc.).



7.3 CHECKS BEFORE SWITCH-ON

Carry out the following checks:

- Check that the protection grid on the hopper is properly secured with the screw shown in the figure (FIG.16-REF.1).

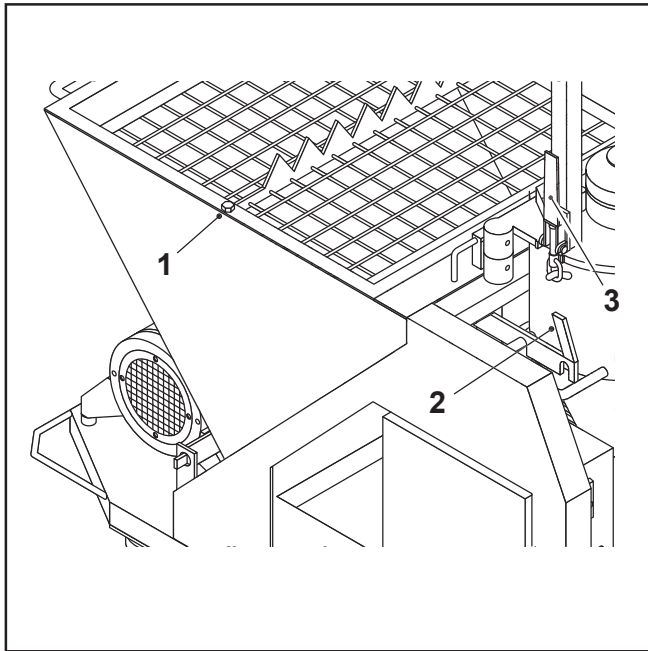

FIG.16

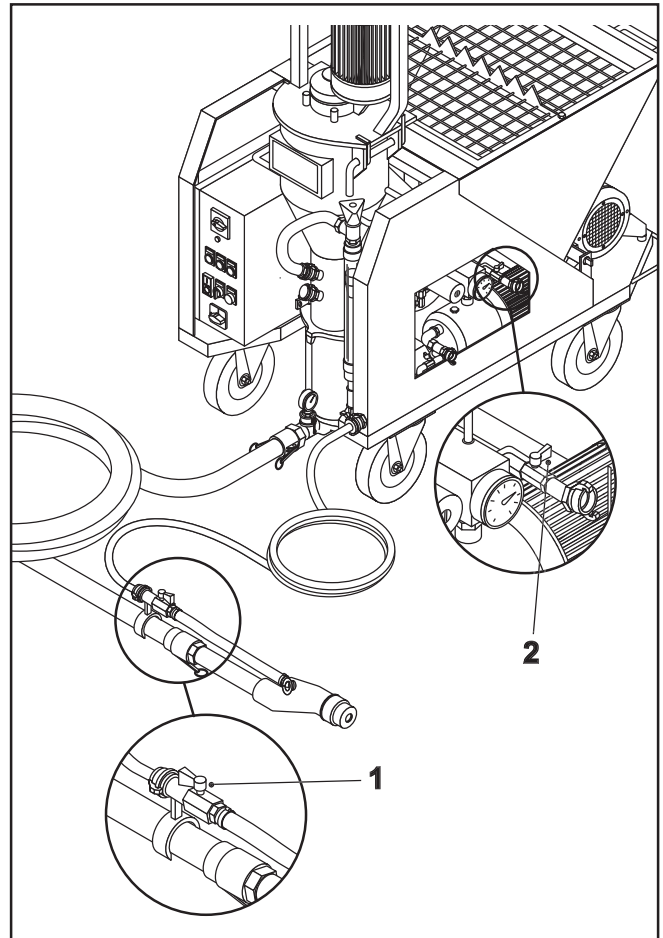

FIG.17

- Check that the mixing unit is properly locked (FIG.16-REF.2) and the gear motor's support closing hook (FIG.16-REF.3) is firmly closed.
- Check that the air cock (FIG.17-REF.1) of the gun is open and the water service cock (FIG.17-REF.2) is closed.
- Check that the dispenser switch, the main disconnecting switch and the water pump switch are at zero.
- Connect the power cable to the socket (FIG.19-REF.1) on the machine's frame.

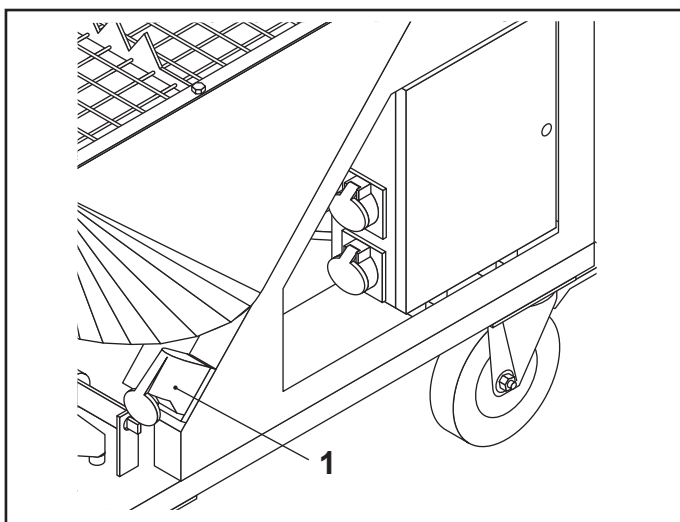

FIG.19



After any repair or maintenance work, make sure all of the protection devices are put back in place and that no tools are forgotten inside the machine.



7.4 CONTROLS

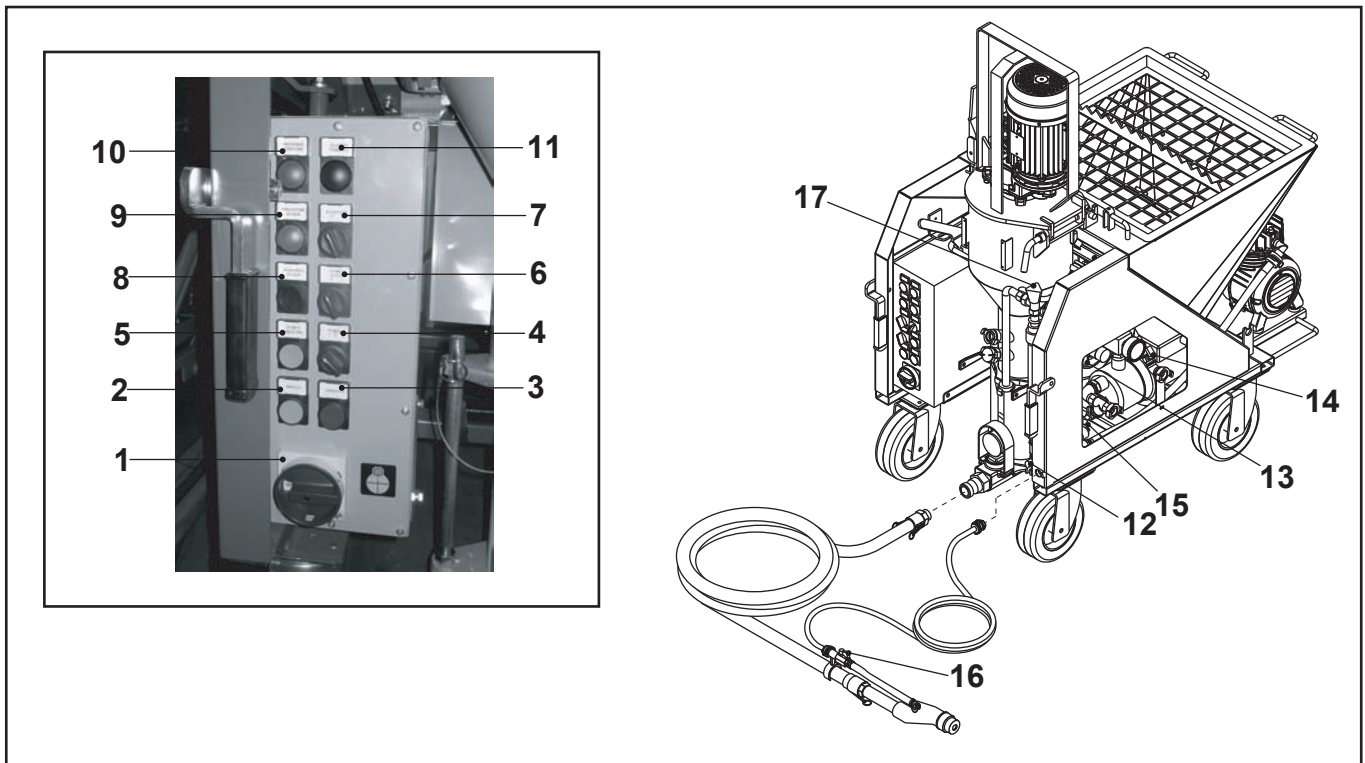

FIG.20

FIG.	REF.	DESCRIPTION
20	1	Main disconnecting switch
20	2	Start
20	3	Stop
20	4	Speed selector
20	5	Mortar pump inversion
20	6	Water pump On/Off
20	7	Dispenser On/Off
20	8	Water supplement
20	9	Water pressure indicator
20	10	Voltage presence indicator
20	11	Overload cutout and safety device tripping

OTHER CONTROLS

FIG.	REF.	DESCRIPTION
20	12	Drain valve
20	13	Drain valve
20	14	Auxiliary valve
20	15	Drain valve
20	16	Start/stop pneumatic control
20	17	Flow meter valve

TAB.07



7.5 MACHINE SWITCH-ON



Use safety gloves to protect against cuts and abrasions and safety goggles that fully protect the eyes, with anti-fog shatterproof lenses.



The gun must never be directed towards the operator or other people.

Start the machine by turning the main disconnecting switch ON: the BLUE indicator lights up. This indicates the correct power supply voltage: with correct voltage the light stays on.

If at start-up the indicator switches off, this means there is not enough voltage.

Make sure the supply line has been properly prepared (cable section and construction site's electrical control board power supply).

Activate the compressor's switch (FIG.22-REF.1).

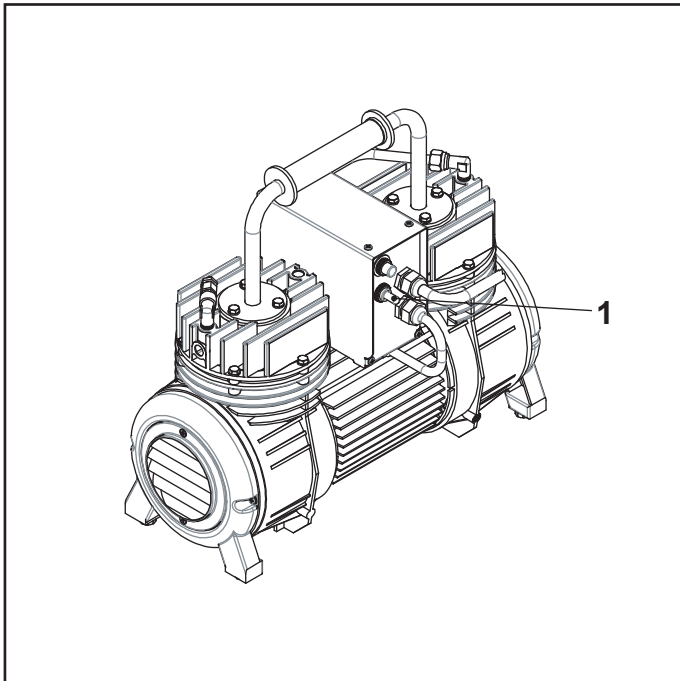

FIG.22

When the main disconnecting switch is ON, the following come one:

- the red indicator (signals anomalies),
- the blue line presence indicator if the line voltage is sufficient,
- the compressor starts working.
- the green water pressure presence indicator lights up when there is enough pressure in the water system, if water is supplied from a drum the green indicator lights up only with the water pump inserted.

Pour the contents of a bag of ready-mixed plaster into the hopper in order to carry out the first adjustments for spraying.

Disconnect the hose (FIG.23-REF.2) the delivers the water to the mixing chamber by pressing and holding the water supplement button (FIG.20-REF.8).

Adjust the flow meter (FIG.23-REF.4) to 500 l/h with the cock (FIG.23-REF.1) and then reconnect the hose (FIG.23-REF.2).

Press the water supplement button for about 3 seconds (FIG.20-REF.8).

When the green button of the start switch is pressed (FIG.20-REF.2) the material pump activates and the red indicator switches off.

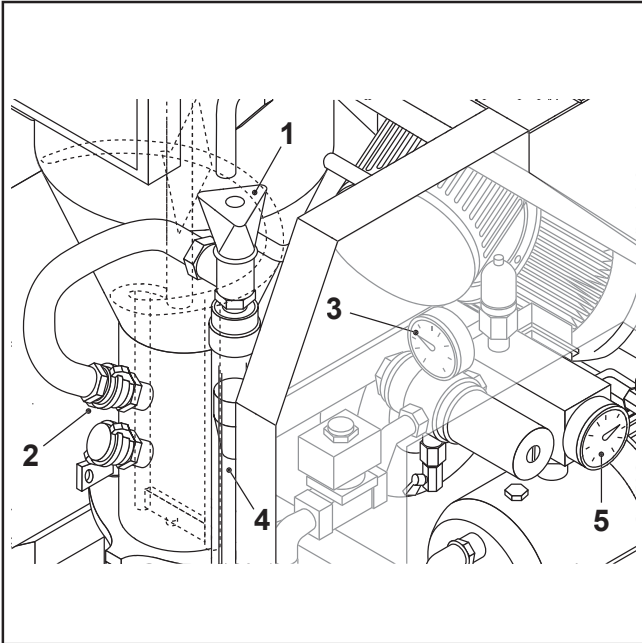

FIG.23

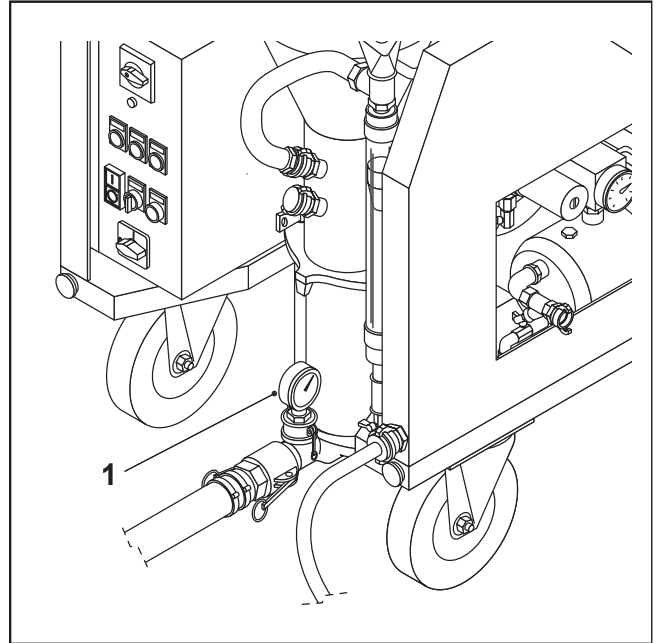

FIG.24

If at start-up the blue indicator switches off, this means there is not enough voltage. Make sure the supply line has been properly prepared (cable section and construction site's electrical control board power supply).

- Engage and disengage the material dispenser switch using the following sequence.
 - 2 seconds on,
 - 2 seconds off, 2 seconds on,
 - 2 seconds off, on.
- Adjust the water flow with the cock (FIG.23-REF.1) until you have the desired consistency.
- Constantly keep the hopper powered with the material.

NOTE: the "normal operating pressure" displayed on the pressure gauge (FIG.24-REF.1) depends on the material and the length of the hoses used; it is useful to regularly check this pressure value to readily detect any anomalies.

Now you can start working normally: the opening and closing of the pneumatic control (FIG.20-REF.16) to the gun starts and stops the machine.



7.6 CLEANING AND END OF WORK



The operator must be specifically trained to carry out this operation.

In particular, before opening a coupling, check the delivery flange pressure gauge to make sure there is no residual pressure in the hoses and, in any case, when stepped on, the hoses must sag. Also make sure that there is no one near. This potentially dangerous operation must always be carried out with the utmost caution, by an experienced person. - Always disconnect the power from the machine, putting the main disconnecting switch (FIG.20-REF.1) on OFF, before removing or reassembling any of the machine's components or accessories.

- Stop the dispenser and continue pumping until only water is output from the gun.
- Stop the material pump.
- Remove the gun and wash it carefully, disassembling the deflector (FIG.26-REF.2).
- Make sure the nozzle hole (FIG.26-REF.1) is clear (if necessary, clean it with specific cleaner).
- Disconnect the hoses from GIOTTO and insert a washing sponge into the hose (FIG.27).
- Connect the water-mortar coupling (FIG.28-REF.3) to the quick coupling (FIG.28-REF.2) of the auxiliary valve and connect the hose to it (FIG.28-REF.4).
- Open the auxiliary valve (FIG.28-REF.1).
- Restart the machine.
- Wash the hose.
- If the pressure to wash the hoses is not enough, turn the water pump on.
- Thoroughly clean the delivery flange removing any deposits that could compromise its proper operation.

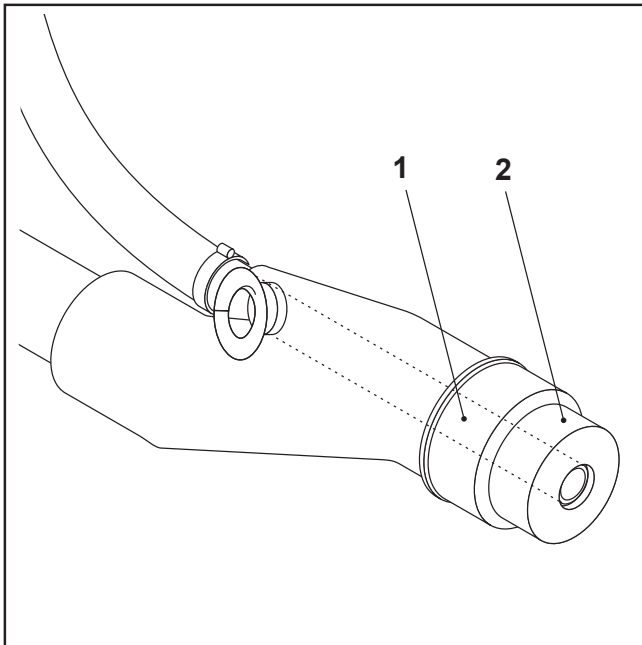

FIG.26

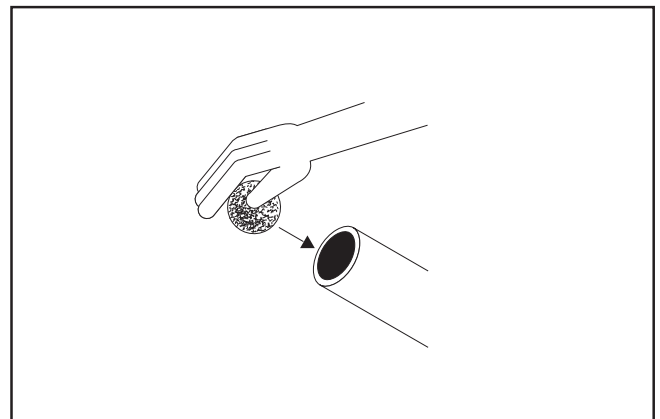

FIG.27

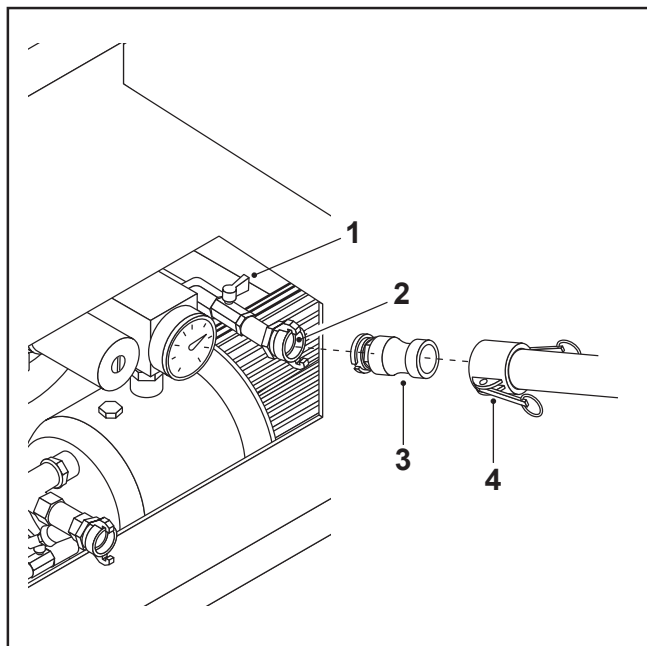

FIG.28

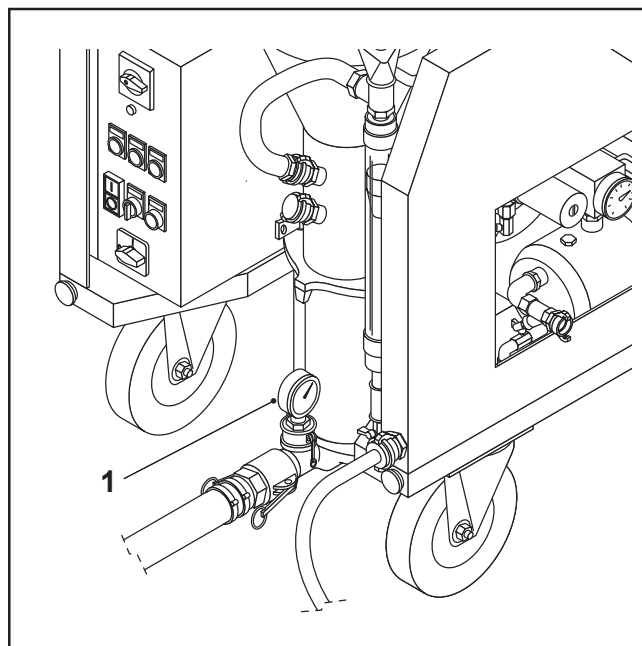

FIG.29

- Disconnect the power from the machine by putting the main disconnecting switch (FIG.31-REF.1) on OFF.
- Open the mixing unit (FIG.30-REF.3).
- Remove the mixer (FIG.30-REF.2) and wash it.

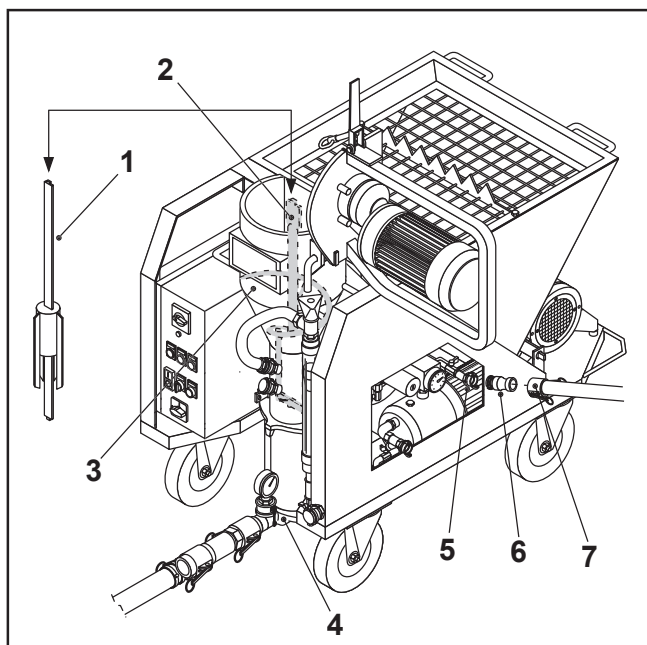

FIG.30

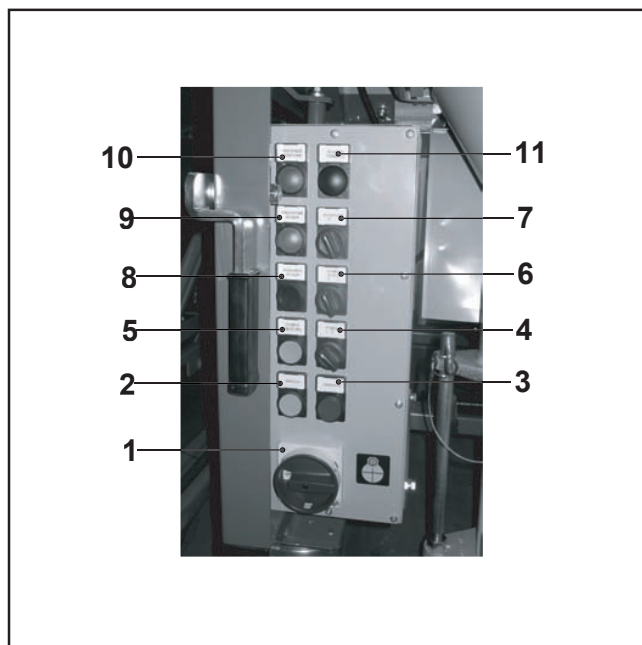

FIG.31

- Insert the scraper (FIG.30-REF.1) in place of the mixer, close the mixing unit and, with the dispenser still stopped, start the material pump by pressing the button (FIG.31-REF.2) until clean water comes out.
- After about 10 seconds or so, stop the material pump by putting the main disconnecting switch (FIG.32-REF.1) on OFF.
- Remove the scraper (FIG.30-REF.1) and clean inside the mixing unit (FIG.30-REF.3) with a cloth.
- Re-insert the mixer. NOTE: If there is a risk of frost, completely drain the water system.

Proceed as follows:

- Put the main disconnecting switch (FIG.31-REF.1) on OFF.
- Disengage the water pump with the switch (FIG.31-REF.6).
- Disconnect the hose (FIG.32-REF.2) from the mixing chamber.
- Connect the air hose (FIG.32-REF.6) to the quick coupling (FIG.32-REF.7) or (FIG.32-REF.5).
- Open the drain valves (FIG.32-REF.1-3-4).
- Start the machine for a couple of minutes by pressing the water supplement button (FIG.31-REF.8) until water can no longer be seen in the flow meter.
- Restore the initial configuration of GIOTTO.



If the machine is not to be used for a long time, thoroughly clean all parts soiled with dust using compressed air (not water as deposits would form). Electric motors tolerate water sprays but not violent jets. Hoses, thoroughly cleaned inside, must be rolled with no creases, and stored in a dark and dry place.

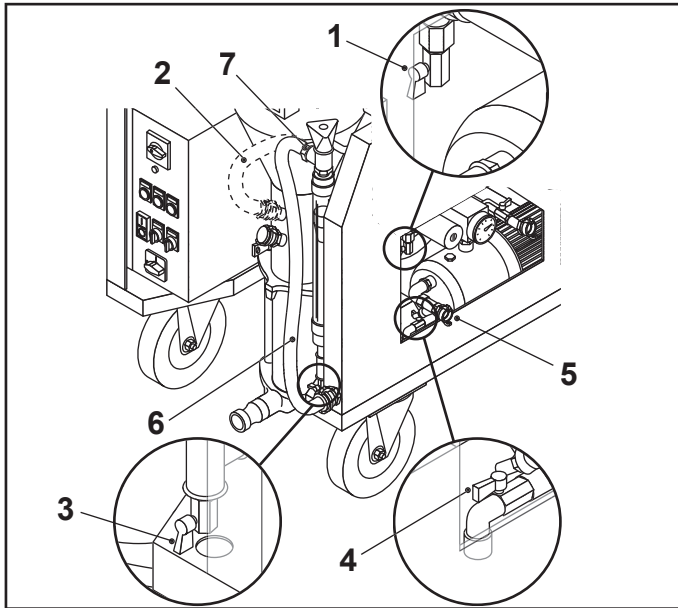

FIG.32



Before cleaning, make sure you read the warnings in paragraph 6.5.

7.7 REPLACING THE PUMPING UNIT

Before carrying out this operation, stop the material pump with the main disconnecting switch and then disconnect the power socket.



The operator must be specifically trained to carry out this operation. In particular, before opening a coupling, check the delivery flange pressure gauge to make sure there is no residual pressure in the hoses and, in any case, when stepped on, the hoses must sag. Also make sure that there is no one near. This potentially dangerous operation must always be carried out with the utmost caution, by an experienced person.

To replace the pumping unit, proceed as follows:

- Incline the mixing chamber unit and block in this position (FIG.33).

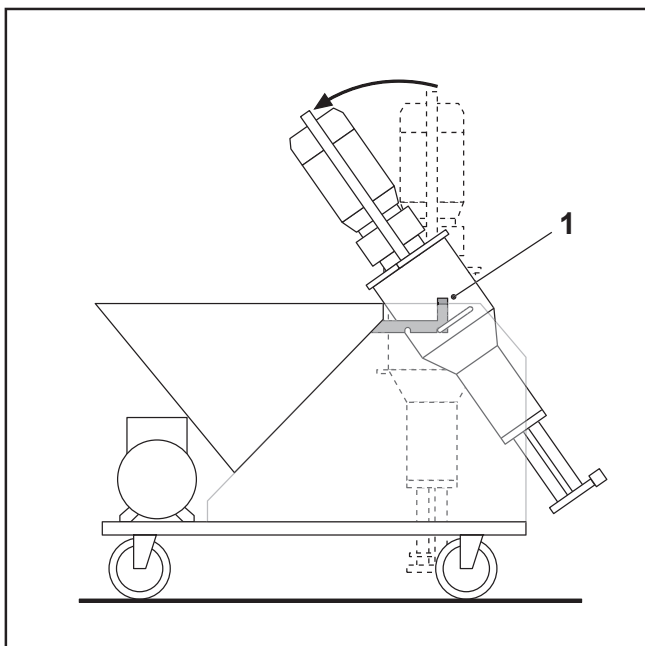

FIG.33

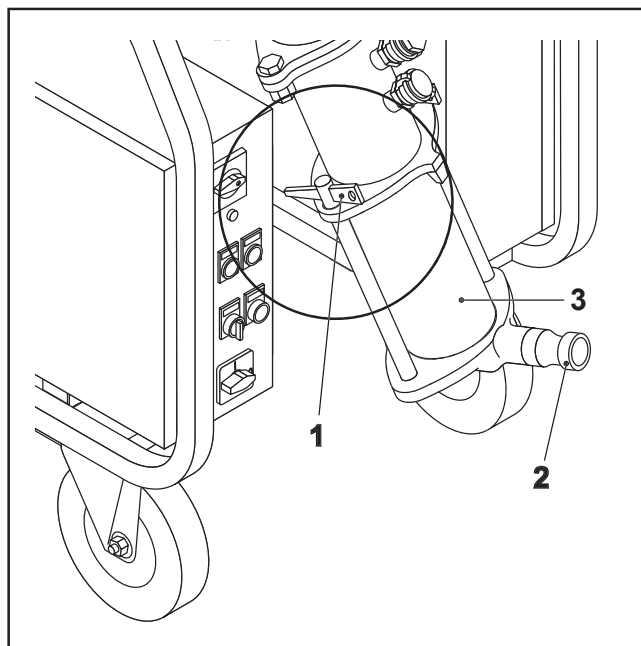

FIG.34

Remove the material delivery flange (FIG.34-REF.2) and the pump (FIG.34-REF.3) by pulling the chocks (FIG.34-REF.1) from the tie-rods.

- Mount a new pump
- Put the mixing unit back into its original position and block it.

Assembling the screw in the stator

Normally, the stator lasts half the time of the screw.

- Disassemble the pump from the machine (see above in the paragraph).
- Grip the pump and extract the screw (FIG.35).
- Grease the screw and the stator mouth with Vaseline (DO NOT USE MINERAL OILS AND GREASES, BUT ONLY VASELINE).
- Partially insert the screw inside the flared mouth.
- Hit the pump (stator + screw partially inserted) repeatedly on a base that does not ruin the stator (e.g. a piece of wood) (FIG.36).

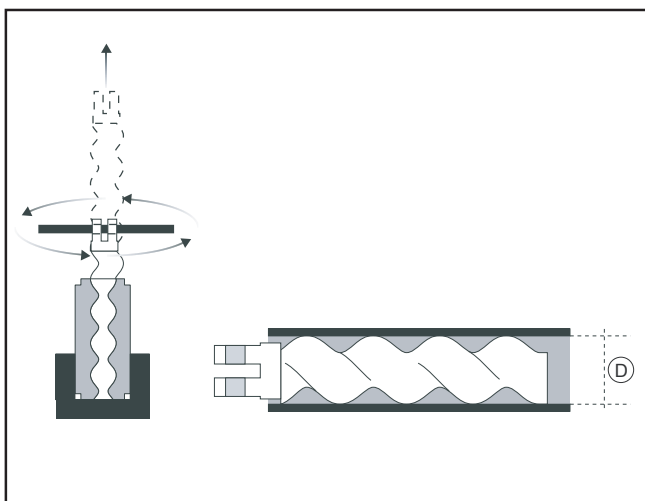

FIG.35

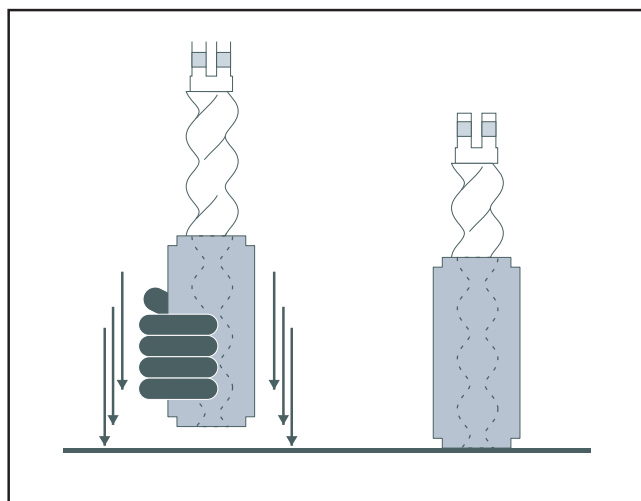

FIG.36

7.8 IMPORTANT WARNINGS



The operator must be specifically trained to carry out this operation.

In particular, before opening a coupling, check the delivery flange pressure gauge to make sure there is no residual pressure in the hoses and, in any case, when stepped on, the hoses must sag. Also make sure that there is no one



near. This potentially dangerous operation must always be carried out with the utmost caution, by an experienced person.

DISASSEMBLY OF THE HOSE LINE

Before disconnecting the hose line, make sure it is not pressurised.

If the line is pressurised:

- disconnect the water hose from the mixing chamber,
- invert the rotation direction of the mortar pump for a few seconds.

With the hose depressurised, put the main disconnecting switch on OFF and then disconnect the hose line.





8 - MAINTENANCE

8.1 OPERATOR RESPONSIBILITY

Below is the essential data for proper machine maintenance.



Switch the machine off before carrying out any maintenance operation that involves opening, removing or assembling any of its components or accessories.

Operations to carry out daily

When beginning work:

- Make sure the water filter (FIG.38-REF.2) is clean.
- Check the efficiency and cleanliness of the delivery flange's pressure gauge.

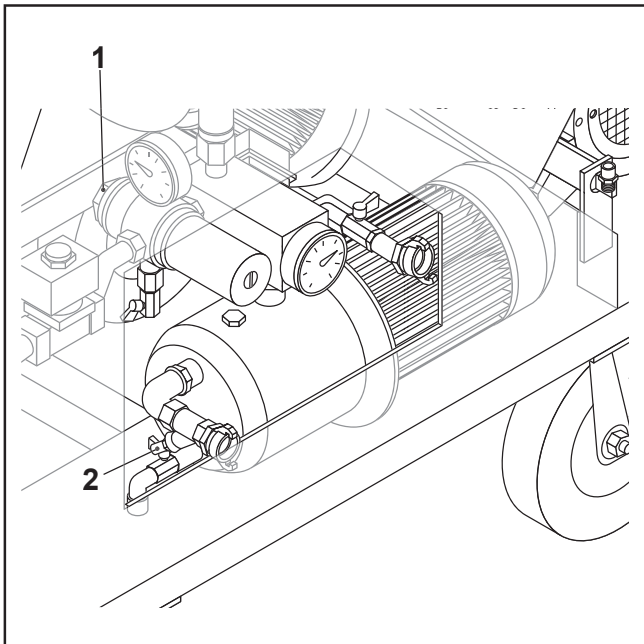

FIG.38

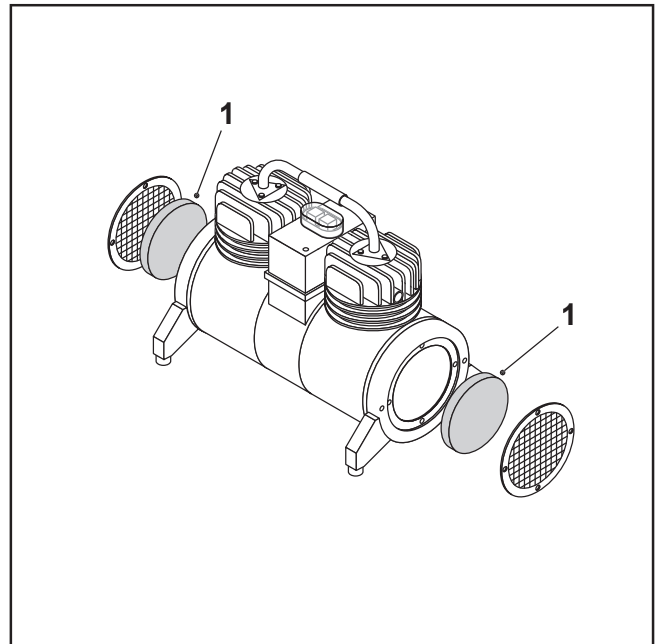

FIG.39

Operations to carry out weekly or every 25 hours

- Make sure the compressor's air filters (FIG.39-REF.1) are clean.
- Make sure the motor gear unit's O-rings are intact, there must be no traces of grease.

Operations to carry out monthly or every 100 hours

- Replace the compressor's air filters (FIG.39-REF.1).
- Use compressed air to thoroughly clean the mixer's main gear motor, the dispenser's gear motor, the compressor and the water pump.

8.2 QUALIFIED PERSONNEL RESPONSIBILITY

Operations to carry out every 6 months or every 500 hours

- Check the air hoses.
- Check the material hoses.
- Service to be carried out by qualified TURBOSOL PRODUZIONE S.p.A. personnel or by TURBOSOL PRODUZIONE S.p.A. assistance centres.





9 - DEMOLITION

9.1 MAIN WARNINGS

When demolishing the machine, it is compulsory to follow the standards in force in the country of use.

Separate the machine parts by type of material (plastic, rubber, iron, etc.).

Oils must be delivered to authorised companies who specialise in the disposal of these products.





10 - TROUBLESHOOTING

10.1 MATERIAL DOES NOT COME OUT OF THE GUN



The operator must be specifically trained to perform the following operations. In particular, before opening a coupling, check the delivery flange pressure gauge to make sure there is no residual pressure in the hoses and ensure there are no other people nearby. This potentially dangerous operation must always be carried out with the utmost caution, by an experienced person.



The "normal operating pressure" displayed on the delivery flange pressure gauge depends on the quality and consistency of the material and the length of the hoses used: it is useful to regularly check this pressure value to readily detect any anomalies. "Normal operating pressure" is a pressure between 15 and 20 bar (with 15 m hose), with instantaneous peaks at about 25 bar. A constant operating pressure above 20 bar or below 10 bar is abnormal.

A) Clogged material hose

An excessively prolonged stop may clog the material delivery hose: material does not come out from the gun and the mortar hose pressure gauge indicates a higher pressure than the normal operating pressure.

In this case:

- Depressurise the hose as described in paragraph 7.8.
- Turn the machine off.
- Check that the pressure indicated by the pressure gauge on the delivery flange is zero.
- Check that the material delivery hose is not hard and stiff anywhere along its length, then disconnect it to release clogging.
- Find where the material delivery line is clogged: the hose will be hard and stiff. Normally, the critical points are the couplings.
- Disconnect the clogged hose.
- With a hammer, tap the stiff part of the hose to break up the obstruction (FIG.40)
- Make the hardened material come out.
- Start the pump for a few seconds and make sure the obstruction has been removed from the hose: the material must come out normally.
- Reconnect the hose line and restart.

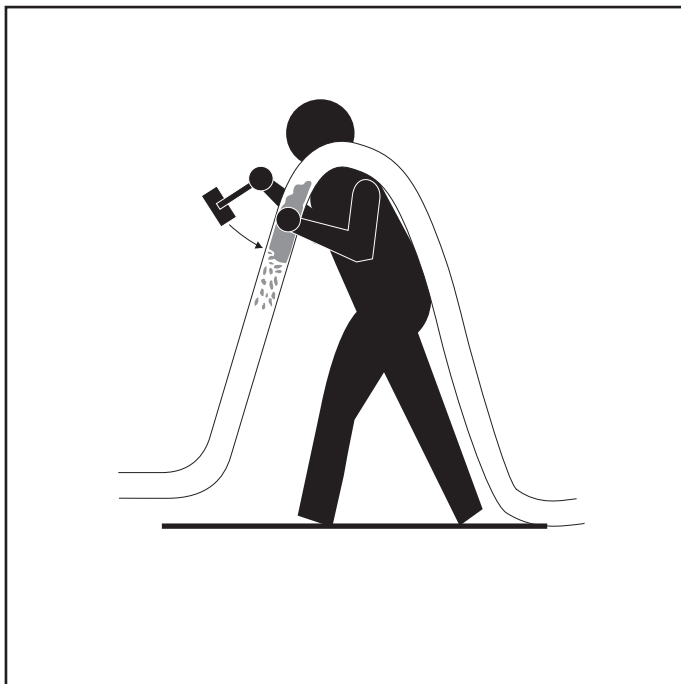

FIG.40

B) Gun clogging

An incorrect mixture, an obstruction (hardened material) or a deflector with a hole too small in relation to the used material, can clog the gun.

- Depressurise the hose pressure as described in paragraph 7.8.
- Turn the machine off.
- Disassemble the deflector and, if necessary, the gun.
- Remove the clogging.
- Before reassembling the deflector or the gun, make sure the nozzle is clear (clean it if necessary) and the material freely comes out of the hose.

C) Worn pump



A worn stator may cause the leakage of material with non-constant features or even clog the top of the hose for material overheating.

- The screw-stator unit must be replaced.

10.2 BLOCKING THE PUMP

If the material pump is blocked, proceed as follows:

- Turn the machine off.
- Open the mixing unit.
- Insert the key to unlock the screw in place of the mixer.
- Move the material pump by turning the key to unlock the screw.
- Close and lock the mixing unit with the lever.
- Restart the machine.

10.3 FUSES/OVERLOAD CUTOUT TRIPPING

The red indicator on the electrical control board lights-up when an overload cutout trips.

The electrical control board does not work when a fuse blows.

- Turn the machine off.
- Open the electrical control board:
or reset the tripped overload cutout,
or replace the blown fuse by referring to the wiring diagram in this manual for the next operations.
- Close the electrical control board, reconnect the power and start the machine.

10.4 OTHER PROBLEMS

If, during operation, material drips from the gun, try replacing the deflector and/or nozzle with one with a smaller hole.

If, during operation, material gets to the gun intermittently, check that the air hose is not bent somewhere or that the air nozzle is not clogged.



10.5 OPERATOR INTERVENTION

PROBLEMS	CAUSES	SOLUTIONS
THE MACHINE DOES NOT START.	No water pressure.	Make sure water is coming from the supply hose. Make sure the water filters are clean. If the pressure gauge of the water system indicates a pressure below 3 bar when the machine is started with the water pump connected, provide a 200 litre container from which the pump must draw.
	No electric power supply.	Make sure the power supply cable is connected.
	Insufficient power supply (blue light off).	Make sure the electric cable has the required features (see Par. 5.4) and that the requested electricity is actually available.
THE MATERIAL PUMP DOES NOT START.	Pump blocked: the overload cutout trips and the red indicator lights up.	Release the pump and replace if necessary (see Par. 10.2 and 7.7). Do not insist with repeated start-up attempts: this may damage the electrical equipment. Make sure the electric cable has the correct features (see Par. 5.4) and that the electric connection has been done properly.
THE MATERIAL PUMP DOES NOT START OR STOPS ON ITS OWN DURING SPRAYING.	Air system partially obstructed.	Make sure the air hose is not bent. Clean the gun nozzle.
	Water is not reaching the mixing chamber (the red indicator lights up to indicate that the overload cutout has tripped).	Make sure the flow meter cock is not completely closed. Make sure the water supply hose to the mixing chamber is not bent.
GUN SPRAYING IS WEAK.	Loss of air in line.	Check the air line and all couplings.
	Clogged compressor filter.	Clean and, if necessary, replace.
THE MATERIAL REACHES THE GUN WITH INCONSTANT FEATURES.	Auger-stator worn.	Check for any wear and, if necessary, replace (see TAB.06 and Par. 7.7).
	Ready-mix deteriorated or nevertheless demixed.	Change material.
	Mixer encrusted.	Clean the mixer.
THE DISPENSER DOES NOT START.	Overload cutout trips, indicated by the red indicator lighting up.	Open the electric control board and reset the overload cutout*. Restart. If the overload cutout trips again, fully empty and clean the hopper. Do not insist with repeated start-up attempts of the machine: this may damage the electrical equipment. If the problem persists, request the intervention of the authorised assistance.

* This is the only operation that the operator is allowed to carry out on the electrical control board.



For any problems not listed above, contact the authorised assistance service.





11 - OPERATOR RESPONSIBILITY

11.1 RESPONSIBILITY

The machine manager must ensure whoever works on it knows the instructions of this manual for use and maintenance and have been specifically trained to correctly execute the operations highlighted herein.

The Manufacturer warranty becomes void if the machinery is not used in accordance with this manual's instructions, that must always accompany the machine.

The machine operator must be educated and trained on its use and operation, must sign this use and maintenance manual next to the phrase "read and approved".

Otherwise, the operator is prohibited from working with this machine.

Manager signature _____

Read and approved _____

Operator signature _____

Read and approved _____

11.2 WARRANTY

Turbosol Produzione S.p.A. machines are covered by a warranty for a 12 (twelve) month period or 1000 hours of work - whichever occurs first - starting from the delivery date of the machine to the Final user and, however, not beyond 18 (eighteen) months from their shipment date. The machine's delivery date to the Final user must be reported on the warranty certificate that must accompany all newly manufactured machines.

The warranty is only valid if the manufacturing company receives the warranty certificate card, duly completed and signed by the purchaser, within 30 days from the machine delivery date.

The warranty covers any manufacturing or material defects.

The goods supplied by Turbosol Produzione S.p.A. but manufactured by third parties are covered by the warranty granted by the latter to Turbosol and that is applied to the Final user.

Only the Manufacturing Company and the Organisations expressly authorised by it can intervene in the event of faults during the warranty period. It is the Final user's responsibility to ensure the machine reaches said Organisations during normal working hours.

The faulty pieces must be sent to the Manufacturing Company ex works, which commits to gratuitously repair or replace those parts that, at its undisputable judgement, show quality defects. The replaced parts remain the manufacturer's property.

The purchaser is responsible for the material shipment expenses and those relating to servicing by the Manufacturing Company's personnel, if required.

The repair or replacement supply will not extend or renew the overall warranty period. Parts subject to normal wear or inducible deterioration are excluded from the warranty, such as: valves seats and rubber ball valves, pistons and jackets, rubber stators and screws, bushes, deflectors, mixing blades, tanks protection armour, wear cones and plates, filters, etc.

The purchaser loses the right to the warranty if the payment conditions are not respected, even only once, should the declared faults be caused: by the actions of the Purchaser, its employees or third parties, when the defect depends on bad use, incorrect installation, improper use or use that is not compliant with the instructions in the use and maintenance manuals received with the machine.

The warranty becomes void if the injection systems are damaged by unsuitable or polluted fuel, in the event of faulty electrical systems due to unsuitable power supply or components like relays, condensers, remote switches, remote controls, etc.: only the supplier warranty applies to these.

The warranty also becomes void due to arbitrary tampering, use of non-original spare parts or rubber hoses different to those supplied by the Manufacturing Company.

The Manufacturing Company is not responsible for any damage caused by the impossibility of using the product or damage due to work interruption or, direct or indirect, profit losses for damages also caused by the removal of casings or protection carters from the moving parts and safety mechanisms.

Flaws and defects must be reported in writing to the manufacturer within the legal terms.

Refer to the original text in Italian in the event of disputed interpretation of the above clauses.

